

**MODELING OF RUMEN PARTICLE
DYNAMICS IN DAIRY COWS FED
SUGARCANE**

EDGAR ALAIN COLLAO-SAENZ

2004

EDGAR ALAIN COLLAO-SAENZ

**MODELING OF RUMEN PARTICLE DYNAMICS IN DAIRY
COWS FED SUGARCANE**

Thesis submitted to Universidade Federal de Lavras as part of the requirements of Post Graduation Program in Animal Science to obtain the degree of 'Doctor' in Ruminant Nutrition.

Advisor
Prof. Paulo César de Aguiar Paiva

LAVRAS
MINAS GERAIS – BRASIL
2004

**Ficha Catalográfica Preparada pela Divisão de Processos Técnicos da
Biblioteca Central da UFLA**

Collao-Saenz, Edgar Alain
Modeling of rumen particle dynamics in dairy cows fed sugarcane /
Edgar Alain Collao-Saenz. -- Lavras : UFLA, 2004.
77 p. : il.

Orientador: Paulo César de Aguiar Paiva.
Tese (Doutorado) – UFLA.
Bibliografia.

1. Ruminante. 2. Modelo matemático. 3. Nutrição animal. 4.
Metabolismo. I. Universidade Federal de Lavras. II. Título.

CDD-636.2085

EDGAR ALAIN COLLAO-SAENZ

**MODELLING OF RUMEN PARTICLE DYNAMICS IN DAIRY
COWS FED SUGARCANE**

Thesis submitted to Universidade Federal de Lavras as
part of the requirements of Post Graduation Program in
Animal Science to obtain the degree of 'Doctor' in
Ruminant Nutrition.

Approved on February 10th 2004

Prof. Jan Dijkstra – WIAS/WAU

Dr. Pedro Braga Arcuri – CNPGL/EMBRAPA

Prof. Juan Ramón Olalquiaga Pérez – DZO/UFLA

Prof. Júlio César Teixeira – DZO/UFLA

Prof. Paulo César de Aguiar Paiva
DZO/UFLA
(Advisor)

**LAVRAS
MINAS GERAIS – BRASIL**

A Antonieta, Obdulia e Lily
OFEREÇO

A minha esposa Juciara
DEDICO

AGRADECIMENTOS

À Universidade Federal de Lavras e ao Departamento de Zootecnia por proporcionar os recursos essenciais para minha formação.

Ao Conselho Nacional de Pesquisa (CNPq) pela concessão da bolsa de estudo e doutorado sanduíche.

Ao meu orientador, Professor Paulo César Aguiar Paiva pela oportunidade de aprendizagem, incentivo e amizade.

Ao Professor Juan Ramón Olalquiaga Pérez pela colaboração e incentivo na realização do estágio no exterior.

Ao Professor Júlio César Teixeira pelo apoio e sugestões no desenvolvimento do presente trabalho.

Aos Doutores Pedro Braga Arcuri e Airdem Gonçalves de Assis do Centro Nacional de Pesquisa em Gado de Leite/EMBRAPA pelo incentivo e colaboração na área de modelagem.

Aos colegas da Pós Graduação Ana Cristina, Ana Luisa, Juliana, Michela, Edinéia, Afrânio, Gustavo, Oiti, Sidnei e Jocélio pelo apoio e companheirismo ao longo do curso.

À turminha: Juciane, Danilo, Maurício, Guilherme, Samuel, Ricardo e Claudionor pela inestimável presença e convivência fraternal.

Às amigas da infância Flávia e Vera pelo estímulo e sincera amizade.

A Dany, Priscila, Marianna, Ivan, Décio e Tarcisio que ajudaram a diminuir a saudade de Lavras.

A todos os professores e funcionários do Departamento de Zootecnia pelos ensinamentos e colaboração e convivência.

To Professor Seerp Tamminga my gratitude for the opportunity to work under his leadership.

To the members of the Animal Nutrition Group of Wageningen Agricultural University, many thanks for the assistance, support and suggestions during my time in The Netherlands.

Special acknowledgment to Barbara Williams and the little Italy for the friendship and the gastronomic meetings in Doorn.

For the clever guidance, time and patience. Jan Dijkstra, Andre Bannink and Walter Gerrits: bedankt!

Diego, Pablo y Bernardo muchas gracias por ayudarme a recordar la casa grande y casi cambiarme el acento español.

...And, he gave it for his opinion, that whoever could make two ears of corn, or two blades of grass to grow upon a spot of ground where only one grew before, would deserve better of mankind, and do more essential service to his country than the whole race of politicians put together....

Jonathan Swift "*Gulliver's Travels*".

CONTENTS

SYMBOL LIST	i
RESUMO	ii
ABSTRACT	iii
MODELLING OF PARTICLE SIZE REDUCTION IN RUMINANTS	1
1 INTRODUCTION	2
Evolution of models representing feed particle size reduction in ruminants	2
2 IMPORTANCE AND QUANTITATIVE APPROACHES OF PARTICLE REDUCTION OF FEED IN RUMINANTS	4
2.1 Representing particle size and digestibility in mathematical models	7
2.1.1 Representing potentially digestible and indigestible fractions	7
2.1.2 Representing rate of particle size reduction and distinct particle sizes	8
2.2 Representing microbial activity on different nutrients and nutrient metabolism	14
2.3 Representation of outflow rate scaled to body weight	17
2.4 Representation of non-steady state conditions	18
3 EVALUATION OF MODELLING EFFORTS	21
4 IMPLICATIONS	25
5 REFERENCES	26
SIMULATION OF RUMEN PARTICLE DYNAMICS USING A MODEL OF RUMEN DIGESTION AND NUTRIENT AVAILABILITY IN DAIRY COWS FED SUGARCANE	32
RESUMO	33
ABSTRACT	34
1 INTRODUCTION	35
2 MATERIAL AND METHODS	37
Model modifications	37
<i>Particle size reduction</i>	37
<i>Dry matter intake</i>	40

<i>Microbial death</i>	41
<i>Salivary nitrogen</i>	42
<i>Rumen volume</i>	42
<i>Cell content release</i>	43
Application of the model	44
<i>Sensitivity analysis</i>	44
<i>Comparisons between simulated and experimental values</i>	45
<i>Evaluation of prediction results</i>	47
3 RESULTS AND DISCUSSION	48
<i>Sensitivity analysis</i>	50
<i>Comparison between observed and predicted values</i>	56
<i>Nutrient outflows and apparent rumen digestion</i>	56
<i>Milk production</i>	61
4 CONCLUSIONS	65
5 REFERENCES	66
APPENDIX	70

SYMBOL LIST

Am	Ammonia;
BW	Body weight;
CWC	Cell wall contents;
DMI	Dry matter intake;
Ex	Escape from rumen;
Fd	Rumen degradable fibre;
Fr _i	Fraction of <i>i</i> ;
Fu	Rumen undegradable fibre;
In	Intake;
Ld	Rumen long chain fatty acids;
Lp	Rumen large particles;
LPR	Outflow of LP due rumination;
LPM	Outflow of LP due microbial attack;
LPT	Transit of LP through the reticulo-omasal orifice;
Mi	Microbial dry matter;
NNA	Non-ammonia nitrogen;
Pd	Rumen insoluble, degradable protein;
Ps	Rumen soluble protein;
Pu	Rumen undegradable protein;
Sc	Rumen soluble starch and sugars;
Si	Rumen insoluble starch;
Sp	Rumen small particles;
SPM	Outflow of SP due microbial attack;
SPT	Transit of SP through the reticulo-omasal orifice;
TDN	Total digestible nutrients;
Va	Rumen volatile fatty acids;
VFI	Voluntary feed intake.

RESUMO

COLLAO-SAENZ, Edgar Alain. **Modelagem da redução do tamanho de partículas dos alimentos em ruminantes**. Lavras: UFLA, 2004. 66p (Tese de Doutorado em Zootecnia – Área de concentração em Nutrição de Ruminantes).¹

O tamanho de partícula influencia o valor nutricional do alimento porque afetar o consumo de matéria seca, desempenho animal, digestão e utilização de nutrientes pelos microorganismos ruminais. No presente estudo, alguns modelos são descritos para representar a redução do tamanho de partícula. Esses modelos procuram simular a disponibilidade de nutrientes para a fermentação ruminal ou prever o consumo de alimento. Em geral, as diferentes propostas se comportam adequadamente e provêm informação útil para produção e pesquisa. Porém, todos os modelos demonstram inexatidão em certos pontos. No presente trabalho são discutidas as razões desses problemas e é proposta a inclusão de novas variáveis relacionadas com a cinética de partículas, ingestão descontínua de alimentos e liberação do conteúdo celular com o objetivo de aumentar a precisão de futuros modelos de consumo e digestão.

¹ Comitê Orientador: Paulo César de Aguiar Paiva – UFLA, Jan Dijkstra – WAU, Júlio César Teixeira – UFLA, Juan Ramón Olalquiaga Pérez – UFLA e Pedro Braga Arcuri – EMBRAPA

ABSTRACT

COLLAO-SAENZ, Edgar Alain. **Modeling of feed particle size reduction in ruminants**. Lavras: UFLA, 2004. 66p (Thesis – Doctorate Program in Animal Science. Major – Ruminant Nutrition).¹

Particle size seems to be an important factor influencing the nutritional value of the feed because it may affect dry matter intake, microbial digestion and utilization of nutrients and, animal performance. Some models are described to present different attempts to represent particle size reduction in function of the modeling objectives, prediction of nutrient supply for the rumen fermentation or describe and simulate the feed intake. In general, the diverse approaches behave adequately and provide useful information for production or research. All the models, however, demonstrate inaccuracy at some points. The reasons for these failures are discussed and inclusion of new variables related to particle kinetics, pulses of feed and cell content release to increase accuracy of predictions in future models of intake and digestion is proposed.

¹ Guidance Committee: Paulo César de Aguiar Paiva – UFLA, Jan Dijkstra – WAU, Júlio César Teixeira – UFLA, Juan Ramón Olalquiaga Pérez – UFLA e Pedro Braga Arcuri – EMBRAPA

**MODELLING OF FEED PARTICLE SIZE REDUCTION IN
RUMINANTS**

1 INTRODUCTION

Evolution of models representing particle size reduction in ruminants

Forage represents an important portion of the energy intake in ruminant production. There are many factors influencing the voluntary feed intake (VFI) by the ruminant. The physical constraints to the intake due to physical attributes of the forages are among the most important. VFI may be limited for ruminants consuming forage as a result of restricted flow of digesta through the gastrointestinal tract causing retention of one or more segments of it and decreasing the intake (Allen, 1996). Considering the physical limitations of the rumen, several dietary and animal factors more or less independent are involved.

Among dietary factors, particle size may be an important factor influencing the nutritional value of the feed because it may affect both dry matter intake, the rate at which nutrients become available for digestion and microbial utilization per unit of feed and animal performance. Based upon the quality of forage, particle size reduction by grinding or pelleting before feeding can increase substantially the intake of forages and other fibrous feeds (Van Soest, 1994).

Particle size is also important in relation to the fractional rate of passage of material out of the rumen. When rumen dry matter content has come to a point where a further increase is not possible, rate of clearance of feed from the rumen determines feed intake (Bosch, 1991). The rate at which the feed is reduced to particles small enough to pass through the reticulo-omasal orifice, and the fermentation rate by the microorganisms, are the most important factors limiting the disappearance of digesta from the rumen.

Meanwhile, most of the particles in the rumen already have an appropriate size to leave but stay showing that other factors mainly related to the animal should be involved. Other factors appear relevant as well, and Martz &

Belyea (1986) also cited particles density, cell wall content or pH and osmotic pressure by their influence in strength and frequency of ruminal and abomasal contractions.

Finally, mastication during the intake of long particles of feed, on the other hand, initiates breakdown of the physical structure of the feed, and the rupture of the cell walls permits the release of soluble cell contents and exposure of cell wall contents (CWC) to microbial enzymes (Weston & Kennedy, 1984). Thus, microbial growth is essentially limited by the digestion rate which, in turn, is limited by intrinsic properties of the feed carbohydrates and protein (Van Soest, 1994).

As the experimental knowledge of the impact of the above mentioned factors on rumen digestion and ruminant metabolism increased, it became possible to develop quantitative approaches further to increase the understanding and to integrate the representation of various aspects. According to Forbes & France (1993), initially, this was achieved by more complex statistical analysis, but in recent years dynamic mathematical models have been developed. These models allow to integrate and to link the impact of essential factors in a mechanistic manner and show where gaps in knowledge remain. Gill (1996) highlighted partition of nutrients, hormonal control, pattern of supply and prediction of intake, as areas where further research is warranted.

The objective of this work is to review the evolution and the importance of the representation of particle size reduction. Some mathematical models will be described to allow understanding of the concepts used and the importance of particle size reduction in voluntary feed intake and metabolism of ruminants.

2 IMPORTANCE AND QUANTITATIVE APPROACHES OF PARTICLE REDUCTION OF FEED IN RUMINANTS.

Maximizing the dry matter intake (DMI) is a key factor for milk production. Laredo & Minson (1973) indicated that the voluntary intake is reduced by low diet digestibility and low rate of passage, and it is therefore assumed that low rates of ruminal digestion and passage may lead to a physical limitation of daily DMI. Retention of digesta is usually sufficiently prolonged for the fibrolytic microbes to digest an appreciable amount of the potentially digestible NDF and satisfy the energy requirements of the animal by production of VFA (Kennedy & Doyle, 1993).

As forage matures, especially in the tropics and subtropics, the poor fermentation of the refractory fibre and the attendant slow passage of digesta through the gut result in low voluntary feed consumption and poor body condition (Kennedy & Murphy, 1988). Thus, a prolonged retention may represent a problem for animals needing high rates of passage to fulfill its requirements. This problem is greater when it is considered that some forage used in tropical regions have a digestibility of NDF between 20 and 30% as sugarcane (Leng & Preston, 1976; Mendonça et al., 2002; Corrêia et al. 2003).

Depending on the quality of forage, particle size reduction usually reduces digestibility and increases intake. This relationship may be less pronounced for low quality forages, because proportionally, its digestibility may be less discounted by particle reduction while intake is increased more (Martz & Belyea, 1986). Dado & Allen (1994) reported milk production to be positively correlated with DMI and negatively with rumination and total time spent chewing per unit of intake. One of the major factors that limit the passage outflow rate of digesta from the rumen is the rate at which the feed is reduced to

a particle size small enough to flow out of the rumen (Poppi et al. 1980). Further, Illius & Gordon (1991) stated that, as food quality declines, passage tends to predominate over digestion in clearance. Although substantial evidence can be found in literature in support of these viewpoints, results are not always consistent. Poppi et al. (1981) observed that cattle and sheep ate more of the leaf fraction than of the stem fraction of tropical grasses, despite the fact that the two fractions had similar potential digestibilities, and they associated the higher intake of leaf with a shorter time that the leaf dry matter (DM) and neutral detergent fiber (NDF) was retained in the reticulo-rumen. The effect of particle size on feed intake, however, remained unclear with inconsistent results being reported for alfalfa based rations mainly (Rode & Satter, 1988; Beauchemin et al., 1997; Yang et al., 2002; Krause et al., 2002; Stanley et al., 1993). Johnson et al. (2003) obtained higher intakes for medium chop (27.8 mm) corn silage compared with long (39.7 mm) chop silage. Woodford & Murphy (1988) concluded that forage particle breakdown was an important factor influencing the intake rate of forages, and for low quality forages in particular, evidence was convincing.

The research about the effects on intake, digestibility and animal performance has basically been developed with high quality forages. It would be necessary to determine those effects on tropical forages with low digestible fiber. Differences between *Bos Taurus* and *Bos indicus* in chewing efficiency and behavior should also be assessed for cattle production in tropical conditions.

McLeod & Minson (1988) proposed that chewing and ruminating are the most important activities to reduce the size of particles. Mastication, however, is not able to account for total breakdown of large particles (LP) and those authors suggested that 17% of LP reduction can be attributed to breakdown by digestion and detrition. Substantial particle size reduction of forages, however, does occur in situ, as a result primarily of microbial activity. This reduction indicates that

ruminal microbes are able to make a useful contribution to particle size reduction of forages during digestion. Particle size reduction began earlier and proceeded more rapidly in legumes when compared with grasses. This ability may be a contributing factor that allows it to leave the rumen more rapidly and may help to explain the greater intake usually observed for animals fed legumes than for those fed grasses (Bowman & Firkins, 1996).

The faster the digesta flows from the rumen, the less time the microorganisms have to ferment it and digestibility decreases. Factors as fineness of grinding may affect the nutritive value of ground or pelleted forage (Moore, 1964). The rate of passage affects the microbial degradation and hence microbial growth because the size of the microbial population will also be reduced due the faster passage. Johnson et al. (2003) reported lower ruminal and total tract digestibility of DM and OM, with cows fed diets containing short chop length (11.1 mm) corn silage. Because of the shorter residence time of the microbes in the rumen, a smaller portion of their maintenance energy requirement will diminish and more microbial biomass can be produced per unit of energy generated from the substrate. Although the combined result on the rumen level is difficult to indicate in general, often a more efficient microbial growth is observed at higher passage rates (Owens & Goetsch, 1986).

In analyzing how animal requirements can be fulfilled in low quality forage systems, the combined effects of shorter retention time, higher passage rate, and higher DMI on the one hand, and higher retention time and more intense digestion of a feed with low digestibility in other, needs to be considered. It is necessary to determine which combination would be better for different levels of animal performance.

2.1 Representing particle size and digestibility in mathematical models

Several models have been proposed to represent the passage and digestion in ruminants. According to Illius & Allen (1994) the first integrated model of this kind was proposed by Blaxter et al. (1956). Baldwin et al. (1970) for the first time, recognized the necessity to include the microbial action and rumination in the reduction of particle size and Waldo et al. (1972) suggested the use of different rates of digestion and escape for different size particle.

Illius & Allen (1994) and Dijkstra & France (1996) made a detailed comparison and described the evolution of the structure and assumptions of intake and digestion models and whole rumen function models respectively. More recent proposals incorporate non steady state conditions and interactions between intake, chewing behavior and digestion (Sauvant et al. 1996) or include age dependent effects related to particle buoyancy (Jessop & Illius, 1999). The concepts applied in these models and the implications that follow from this will be discussed below.

2.1.1 Representing potentially digestible and indigestible fractions

One of the first mathematical approaches (Waldo et al., 1972) barely represented disappearance from the rumen and divided fiber components free of lignin in potentially digestible and indigestible due to plant factors, and described both digestion and passage as first-order reactions (Figure 1). The potentially digestible fraction disappears by both different rates of digestion and passage whereas the disappearance of the indigestible pool occurred just by passage.

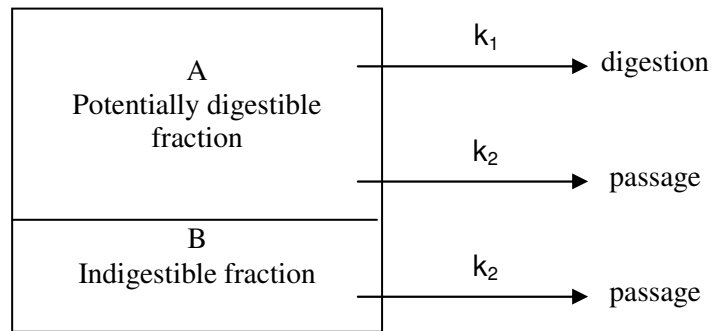

Figure 1 Model of rumen cellulose disappearance; k_1 and k_2 are rate constants for digestion and passage respectively (Waldo et al., 1972)

2.1.2 Representing rate of particle size reduction and distinct particle sizes.

Allen & Mertens (1988) reviewed different approaches to model the constraints to fiber digestion and verified that rumen fiber may be separated by probability of escape from the rumen as well as by resistance to digestion. Hungate (1966) suggested that the rumen consists of a rumination pool, which consists of large particles (LP) that cannot pass through the reticulo-omasal orifice, and a pool of small particles (SP) able to escape from the rumen.

As observed, one of the major factors limiting the disappearance of digesta from the rumen is the rate at which the feed was reduced to particles small enough to pass out the rumen. In this way and based in the Blaxter et al. (1956) compartmental system, Mertens & Ely (1979) developed a dynamic model including kinetics of passage, particle size reduction and digestion of fiber fraction from the digestive tract of ruminants. In the particle size reduction submodel they used three compartments including large (>2mm), medium (0.5 to 2 mm) and small (<0.5 mm) particles (Figure 2). Medium particles (MP) could escape from the rumen but at a slower rate than SP. They concluded that more research is needed to represent particle size distribution and the processes linked to comminution and its effect on the rate of passage. Mathematically that could be represented by the probability of a particle in conditions to escape (size,

density, etc.) to be close to reticulo-omasal orifice at the time of a ruminal contraction.

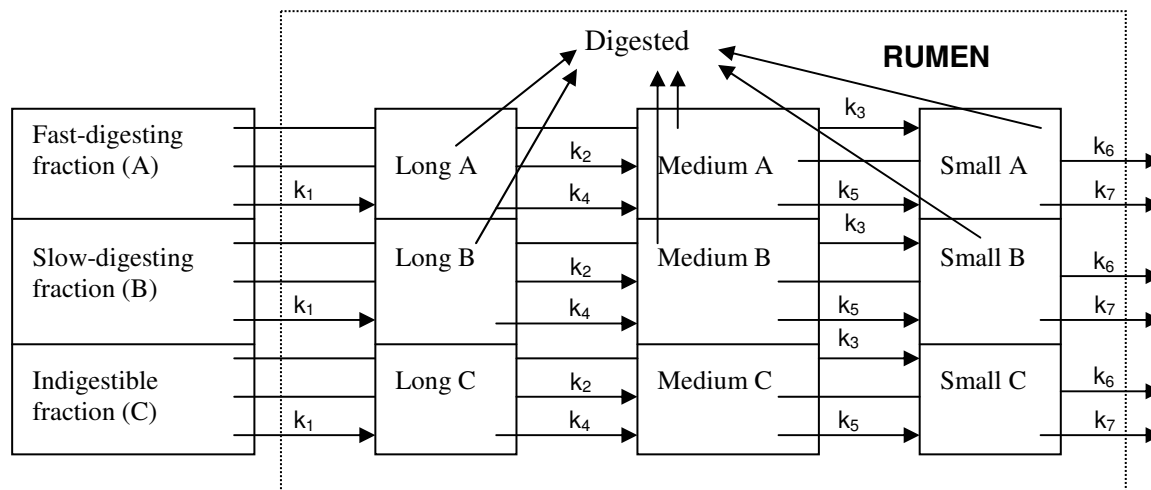

Figure 2. Model of fiber dynamics through the rumen. k_1 , k_2 and k_3 are proportions of large, medium and small particle respectively in the feed; k_4 and k_5 , particle size reduction rates between compartments; k_6 and k_7 , rate of passage of medium and small material from the rumen (Mertens & Ely, 1979).

Since there is virtually no change in the size of digesta once they had left the rumen Poppi et al (1980). Measurement of particle size of material flowing from the rumen can be done on faecal samples which are easier to collect than material from the abomasum. Although particle above critical size may escape from the rumen, Poppi et al (1980) found less than 5% of particles passing a sieve of >1.18 mm in faeces of sheep fed with two legumes and three tropical grasses. The authors suggested that if a simple two-compartment model is used, the critical size of about 1.18 mm may be useful. Later, Poppi et al. (1981) reported that 4.5% of the cattle faecal particle was retained on a 1.18 mm sieve and made a recommendation to use a 1.18 mm sieve to divide the rumen contents of both cattle and sheep into LP and SP pools. Although most of the models follow this recommendation, Bruining et al. (1998) observed higher fractions (between 11.1 to 14.0%) of faecal DM retained on the 1.25 mm pore size sieve. Higher threshold sieve aperture sizes in the range of 3 to 4 mm have been reported for steers (Dixon & Milligan, 1985), > 4mm (Cardoza & Mertens, 1986) and > 4.25 mm (Woodford & Murphy, 1988) for dairy cattle. Shaver et al. (1988) found 24 to 36% of faecal DM retained on screens >1.18 mm and suggested that critical size for escape of particles from the rumen in cattle appears to be greater than 1.18 mm with a threshold size of 3.6 mm. Based in several measurements of faecal particle size made in both cattle and sheep, Ulyatt et al. (1986), concluded that the threshold particle size in cattle is 1.5 to 2.0 times that of sheep. The threshold is variable due to physical form and DMI (Van Soest et al., 1988) and cannot be measured in absolute terms because of biological randomness in the passage of digesta particles (Deswysen & Ellis, 1990). The minimum limit is probably linked with the extension of reticular contractions as an intrinsic feature of each individual. Okine & Mathison (1991) found that duration and amplitude of contraction are more associated with duodenal NDF flow than frequency. On an individual basis, duration of reticular

contraction explained a greater variation in duodenal NDF flow than amplitude. They concluded that the changes in digesta passage from the ruminoreticulum were associated primarily with changes in the duration of reticular contraction.

Different models have been published including a representation of the rate of breakdown (comminution) of large particles (LP) to small particles (SP). Although the general concept used is similar, these models present different ways of parameterization. In order to describe the kinetics of LP and SP through the rumen, Poppi et al. (1981) presented a steady-state model in which the feed goes directly into either a large or small pool. The food content was just separated in digestible and indigestible fractions (Figure 3). The LP can disappear by digestion (k_1), breakdown to small particles (k_3) or escape (k_4), while the SP disappear by digestion (k_2) and passage (k_5). The retention time of LP determined in the study is the reciprocal of the sum of k_1 , k_3 and k_4 . The breakdown of LP seems to be the major pathway affecting the disappearance of LP and considers three processes: comminution by digestion, detrition by rumen movements and rumination. Nevertheless, the relative importance of the three processes was not evaluated. The simulation showed a greater effect on the retention time of DM by increasing the digestion (k_2) and passage (k_5) of SP (decreasing the retention time of SP) than the effect of increasing the rate of breakdown of LP. They concluded that although the retention time of LP is a factor affecting retention time of DM in the rumen, it does not seem to limit the clearance of the digesta, and retention time of SP is probably a more important factor. Therefore, changes in the rate of breakdown of LP have small effect on DM retention time. Considering the conclusions of this model, the sum of the outflows from the LP pool could be simplified using just the comminution rate as unique outflow from the LP pool for ruminants eating mostly roughage.

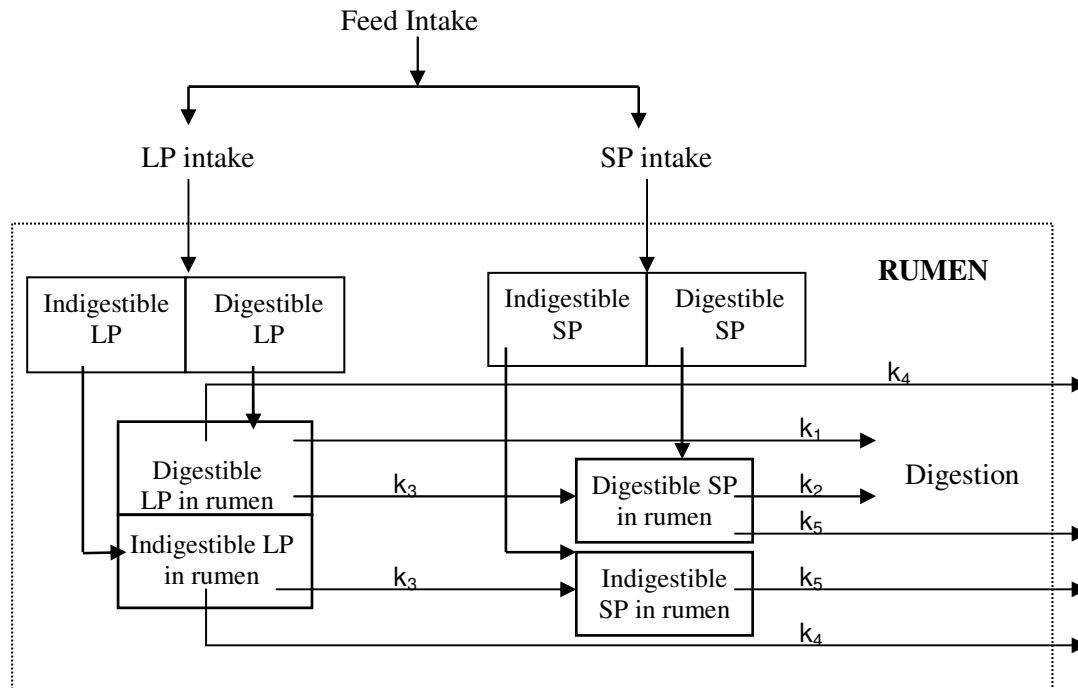

Figure 3. Flow of dry matter through the reticulo-rumen. k_1 and k_2 are digestion rates of large and small particle respectively; k_3 , breakdown to small particles; k_4 and k_5 , rate of passage of large and small particles respectively from the rumen (Poppi et al., 1981).

2.2 Representing microbial activity on different nutrients and nutrient metabolism

Baldwin et al. (1970) proposed a rumen model with chemically defined substrates from the diet affected by the activity of three microbial groups. Between the substrates, the holocellulose, composed of hexose and pentose polymers, was separated in two physical forms. The model evolved continuously and Baldwin et al. (1977) differentiated particles in LP and SP. A tentative of Murphy et al. (1986) to correct the passage values for low quality forage by the addition of a third particle size pool of hemicellulose and cellulose did not improve the behavior of the model.

Baldwin (1995) proposed a modified single microbial population affecting the SP pool of the insoluble dietary nutrients. The SP pool is calculated as the sum of five individual state variables of rumen contents of small-particle starch, cellulose, hemicellulose, insoluble protein and lignin plus insoluble ash. Instead of considering one LP pool for each component, as Mertens & Ely (1979) or Poppi et al. (1981) did, the LP pool is represented by a single aggregate state variable comprising cellulose, hemicellulose, lignin, insoluble ash and insoluble protein. The total microbial pool is distributed among the LP, SP, and soluble pools proportionally to the DM in each pool. Differential attachments of microbes to LP and SP are considered, and the microbial flow rates are related with LP and SP flow rates. The microorganisms act over the aggregated SP and some equations were included to represent, first, specific growth of microorganisms on their specific substrates, and second, to represent the association of micro-organisms to these substrates.

Depending upon the fraction of nutrients in SP form and upon the solubility of nutrients, ingested feed enters the LP pool, the SP pool, or the water-soluble pool. The conversion of LP to SP is totally dependent upon rumination (Figure 4). Differently of the model proposed by Poppi et al. (1981),

LP cannot pass from the rumen and no hydrolysis and fermentation of LP components can occur. Components of the SP pools can pass from the rumen or enter the soluble pools as a result of degradation. Differently from microorganisms in LP, those in SP and soluble pools can pass from the rumen.

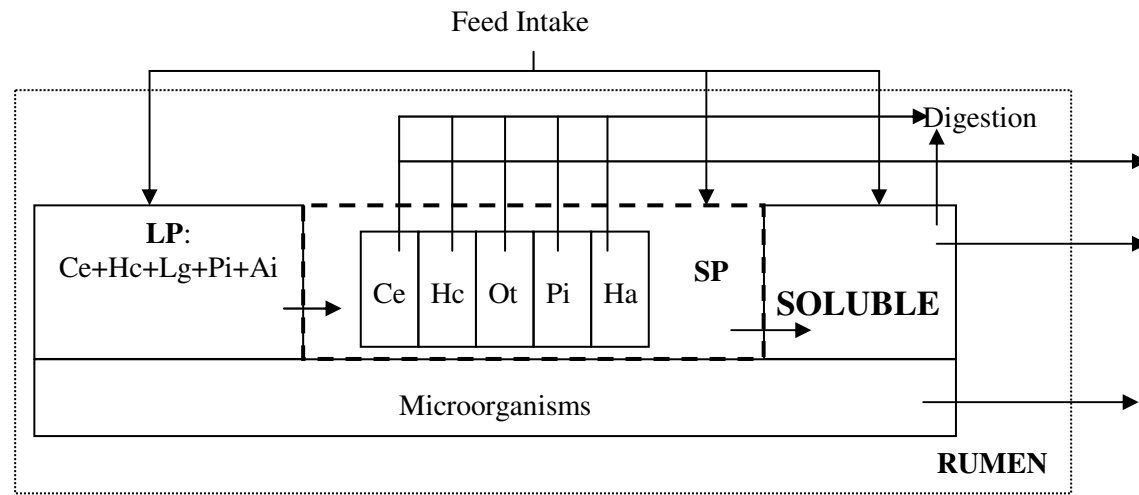

Figure 4. Microbial activity as a function of rumen concentrations of soluble, large and small-particle nutrients and microorganisms associated to these fractions, the concentrations are calculated by using rumen fluid volumes (Baldwin et al., 1987). Ha, starch; Ce, cellulose; Hc, hemicellulose; Lg, lignin; Pi, insoluble protein; Ai, insoluble ash; Ot, Insoluble ash plus lignin.

The conversion rate to small particles is represented by multiplying the comminution rate for the proportion of time spent ruminating per unit time or ruminating factor. This factor can be specified as an input parameter with steady state simulations or calculated using an equation of Murphy et al. (1983) for discrete meals. According to the latter equation rumination stops during feeding when the animal is fed twice daily. In continuous feeding a constant ruminating factor is assumed.

2.3 Representation of outflow rate scaled to body weight

Illius & Gordon (1991) proposed a mechanistic model detailing the intake and digestion of forages and incorporated scaling relationships of comminution, digestion and passage with the body weight, (BW) assuming that large animals should have superior capacity to process foods relative to their requirements and, therefore, should be able to tolerate lower quality forages than smaller animals. The digestible and indigestible cell wall fractions are divided into pools containing large and small particles (those capable of being passed through a 1mm screen). After ingestion a lag time was considered counting for the time necessary for hydration and microbial attachment and assuming no passage of food components during this phase.

Besides the comminution of the LP to SP before its passage from the rumen, the model accounts for a very small percentage of the LP cell wall fraction also flowing out of the rumen at an escape rate. LP pool is available to be digested and the model assumes that digestion rates of LP and SP are the same.

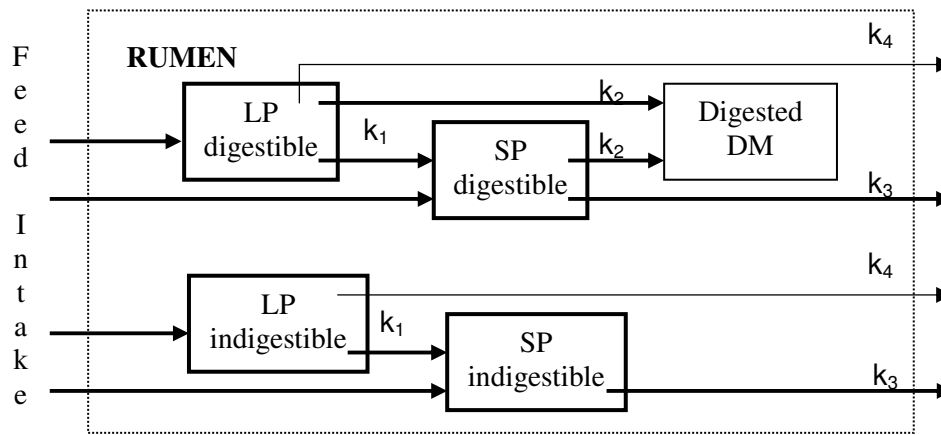

Figure 5. Model of forage digestion in ruminants. k_1 , breakdown rate of large particles to small; k_2 , digestion rate; k_3 and k_4 , passage rate of small and large particles respectively from the rumen; (Illius & Gordon, 1991).

2.4 Representation of non-steady state conditions

Ruminants do not eat and drink continuously during the day. France et al. (1982) proposed for the first time, discontinuous pulses to the rumen in a model without differentiation in particle size. In order to predict dry matter intake (DMI) in non-steady state conditions, Sauvant et al. (1996) developed a model linking two submodels of feeding behavior (motivation and inhibition of intake) and digestion in sheep. In the digestion submodel, the particle mass is also divided in two pools; LP retained by a 1mm sieve and, SP with higher probability to escape from the rumen without comminution.

The LP and SP pools, however, were subdivided in two subpools describing LP or SP in the lag phase just after intake and before digestion start. After the lag, the two subpools were divided into three fractions: digestible cell wall, cell contents and indigestible dry matter. The inflow for the LP pool is the product of the proportion of LP in the swallowed bolus (predicted from the LP ingested bolus) and two variables concerning animal behavior, live weight, energy balance, rumen volume and daily energy requirement. Even with a higher

level of aggregation for dietary chemical fractions and microbial activities, they used the assumption of Baldwin et al. (1987) that the distribution of nutrients in the rumen is the same in large and small particles for each chemical constituent.

To explain and predict the variation in intake rate they also considered feed attributes like an interaction between the proportion of large particles in the diet and the cell wall content corrected by a factor counting for the palatability. The outflows of the LP pool (LPR) were due to rumination, microbial attack (LPM) and transit through the reticulo-omasal orifice (LPT). The three LP outflows considered particle size in its determination. The kinetics of the SP pool has the same principles but LP outflow due to rumination acts as an inflow (Figure 6). Contrary to the previous model of Illius & Gordon (1991), the feed degradation rates were different for LP and SP pools.

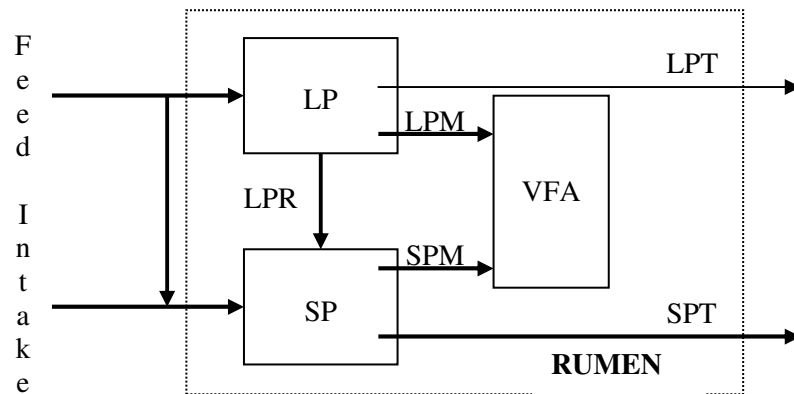

Figure 6. Degradation and passage in the rumen. LPR, outflow of LP due rumination; LPM, outflow of LP due microbial attack; LPT, transit of LP through the reticulo-omasal orifice; SPM, outflow of SP due microbial attack; SPT, transit of SP through the reticulo-omasal orifice. Sauvante et al. (1996)

Differently from previous models Sauvant et al. (1996) included an autonomous non-steady state system considering the influence of feeding behavior and ruminal motility to predict outflow rates instead of use constant values. Comminution was an output variable instead of an input, which is calculated from the quantity of DM in the reswallowed bolus and the comminution rate per bolus. Microbial digestion did not influence particle comminution in the model and the comminution rate was not a sensitive parameter. They concluded that the large range of published values for the comminution rate does not seem to be important to determine voluntary DMI.

3 EVALUATION OF MODELLING EFFORTS

The different models described above present several attempts to represent particle size reduction in function of the modeling objectives, some of them aim the prediction of nutrient supply from the rumen fermentation, whilst others represent particle size reduction as a way to explain, describe and simulate the level of feed intake. It has been demonstrated that the filling effects of low digestibility forages may affect the performance of ruminants (Dado & Allen, 1996; Oba & Allen, 1999). In these circumstances a reduction of the particle size of feeds might contribute to an increased feed intake in addition to the effects of rumination. According to Forbes (1996), it is unrealistic to try to predict intake of forages merely based on the physical attributes of the feed (particle size, cell wall content) and animal (gut capacity), although in some cases these factors seem so dominant that prediction of intake from these attributes is sufficiently accurate.

Although the diverse approaches behave adequately in general and provide useful information for production or research, all the models demonstrate inaccuracy at some points. The problem appears to be a lack of knowledge on specific aspects of rumen function, making it difficult to simulate pathways on which in fact more research should be conducted first. Illius & Gordon (1991), for example, mentioned as disadvantage of the models, the necessity to use simplified assumptions where data are lacking. In their case specifically they cited assumptions related to the growth or passage rate of microbial mass or factors affecting lag times. Murphy et al. (1986) identified particle size reduction and passage from the rumen as critical areas of the Baldwin et al. (1977) model that needed further research. Bruining et al. (1998) observed that it is still not completely clear to what extent the intake of roughage

is limited by rumen processes such as fermentative degradation, comminution and passage.

In the intention to accurately represent the particle dynamics in the rumen, several models included more than two particle size pools (Mertens & Ely, 1979 and Kennedy & Murphy, 1988). Poppi et al. (1980), however, suggested that a two-pool system with large and small particles pools provided advantages in quantifying the processes involved in the reduction of particles size. Sauvant et al. (1996) argued that the use of more than two sizes of particle to improve the simulation of digestion is not feasible because a higher number of particle compartments increases the problem of the lack of information on the flows linking them. Attempts to include more pools (Murphy et al., 1986) in models originally with two pools, did not bring more accurate predictions. The simulations with two pools seem to be sufficiently accurate for the objectives of the current models. More particle size pools would need a higher level of parametrization. If we consider that a model should be precise and at the same time simple, two-particle size pools seems to be adequate for the current level of knowledge.

Most of the models assume first order kinetics to describe processes of digestion and passage. Nevertheless, besides particle size, the particle buoyancy, sometimes represented as its inverse, the particle specific gravity, are also factors which have been demonstrated to influence the flow of food material through the rumen (Poppi et al., 1981; Lechner-Doll et al., 1990; Jessop & Illius, 1999). Changes in particle buoyancy during the particle digestion may result in a process of passage of particles from the rumen for which the assumption of first order kinetics does not hold. To determine the effects of buoyancy on passage, Jessop & Illius (1999) included separate sets of compartments for components of each meal in the model of Illius & Gordon (1991). The inclusion of the effects of age of fragments related to particle density allowed the model to let passage rate

vary with particle age, and it affected mean retention time and DMI. This representation of buoyancy did improve the relationship between DMI predicted and observed. On the other hand, Sauvant et al. (1996) decided to neglect the influence of particle specific gravity because it was assumed to be closely linked with particle size. More specific modeling approaches would be necessary to include particle specific gravity representation. Nevertheless, the utilization of some constants accounting for a “buoyancy factor” for specific forages and including this into newly developed models may help to represent the passage features observed more appropriately.

The frequency of meals and the amount ingested by ruminants are not constant during the day. Depending on the structure of the model, the features related to particle size reduction mentioned above could not affect the quantity of nutrients absorbed by the ruminant in models assuming continuous feeding. Nevertheless, when discontinuous feeding patterns are evaluated these features become important. According to Dijkstra & France (1996) the representation of discontinuous feeding patterns has not received much attention in rumen models, and the simulation of varying pool sizes with time can be of importance, specially when asynchronous diets are fed discontinuously to ruminants. There is little quantitative information on how the frequency of feeding affects the pattern of nutrient supply (Gill, 1996). As observed in models of whole rumen (Dijkstra & France, 1996) or intake (Sauvant et al. 1996), the representation of outflow from the rumen requires a more mechanistic approach in different feeding patterns to indicate the most appropriate time intervals or to explain variations on the intake. Non steady-state models, however, should consider the necessity to include auxiliary variables to simulate the behavior of the microbial mass in the absence of nutrients during the periods without nutrient inputs.

Finally, all the cited models assume a single fractional degradation rate and immediate availability of all plant components for fermentation. Boudon &

Peyraud (2001) and Kingston-Smith et al. (2003) however, postulate that there is a variation of the released proportions of cell contents after the break of the cell wall and as a consequence an effect in the digestion of intracellular constituents. Boudon & Peyraud (2001) proposed that initially chewing of fresh forages releases relatively little of the cell constituents because some constituents can only be released if the plant cell wall and the plasma lemma are broken. They concluded that characterization of the release kinetics of the intracellular constituents is necessary to determine if release could be a limiting step in the process of degradation. Although this aspect seems relevant for representing rumen function, no modeling efforts are known to represent the effects of a differential rate of release of plant cell constituents. The inclusion of the cell content release could be done by the aggregation of state variables representing the unavailable nutrients before to become available in dependence of mastication, rumination and the different fractions of nutrients (soluble sugars, non protein nitrogen, etc.).

In conclusion, mechanistic approaches to represent effects of particle size reduction, passage rate, as well as the release rate of cell contents in non steady-state conditions may allow an improved representation of the effects of particle size and of discontinuous feed intake on rumen function.

4 IMPLICATIONS

Particle size reduction should be taken in account in simulation of intake and digestion of low quality forages. The current lack of knowledge makes it difficult to give the mathematical representation of the phenomena involved in particle kinetics. The models proposed, however, are important tools to test de effects of different ingredients or diets on animal production. Even though the representation of variables as buoyancy, pulses of feed and cell content release seems to be complex, simplified approaches might give reasonable accuracy. The inclusion of these variables in future models may increase significantly the predictions accuracy of intake and digestion during the day.

5 REFERENCES

- ALLEN, M. S. Physical constraints on voluntary intake of forages by ruminants. **Journal of Animal Science**, Savoy, v. 74, n. 12, p. 3063-3075, Dec. 1996.
- ALLEN, M. S.; MERTENS, D. R. Evaluating constraints on fiber digestion by rumen microbes. **Journal of Nutrition**, Bethesda, v. 118, n. 2, p. 261-270, Feb. 1988.
- BALDWIN, R. L. **Modeling ruminant digestion and metabolism**. London, Chapman & Hall, 1995. 592 p.
- BALDWIN, R. L.; KOONG, L. J.; ULYATT, M. J. A dynamic model of ruminant digestion for evaluation of factors affecting nutritive value. **Agricultural Systems**, Barking, v. 2, n. 4, p. 255-288, Oct. 1977.
- BALDWIN, R. L.; LUCAS, H. L.; CABRERA, R. Energetic relationships in the formation and utilization of fermentation end-products. In: PHILLIPSON, A. T. Physiology of digestion and metabolism in the ruminant. **Proceedings...** Newcastle: Oriel Press, 1970. p. 319- 334.
- BALDWIN, R. L.; THORNLEY, J. H. M.; BEAVER, D. E. Metabolism of the lactating cow. II. Digestive elements of a mechanistic model. **Journal of Dairy Research**, Cambridge, v. 54, n. 1, p. 107-131, Feb. 1987.
- BEAUCHEMIN, K. A.; RODE, L. M.; ELIASON, M. J. Chewing activities and milk production of dairy cows fed alfalfa as hay, silage, or dries cubes of hay or silage. **Journal of Dairy Science**, Savoy, v. 80, n. 2, p. 324-333, Feb. 1997.
- BLAXTER, K. L.; GRAHAM, N. M.; WAINMAN, F. W. Some observations on the digestibility of food by sheep and on related problems. **British Journal of Nutrition**, Cambridge, v. 10, n. 2, p. 69-91, 1956.
- BOSCH, M. W. **Influence of stage of maturity of grass silages on digestion processes in dairy cows**. 1991. 150 p. Thesis (Ph. D. in Animal Nutrition) Wageningen Agricultural University, Wageningen, The Netherlands.
- BOUDON, A.; PEYRAUD, J. L. The release of intracellular constituents from fresh ryegrass (*Lolium perenne* L.) during ingestive mastication in dairy cows: effect of intracellular constituent, season and stage of maturity. **Animal Feed Science and Technology**, Amsterdam, v. 93, n. 3/4, p. 229-245, Oct. 2001.
- BOWMAN, J. G. P.; FIRKINS, J. L. *In Situ* Particle Size Reduction as Affected by Forage Species and Grinding Mesh Size. **Journal of Animal Science**, Savoy, v. 74, n. 2, p. 439-446, Feb. 1996.

- BRUINING, M.; BAKKER, R.; BRUCHEM, J. van; TAMMINGA, S. Rumen digesta kinetics in dairy cows fed grass, maize and alfalfa silage. 1. Comparison of conventional, steady-state and dynamic methods to estimate microbial degradation, comminution and passage of particles. **Animal Feed Science and Technology**, Amsterdam, v. 73, n. 1/2, p. 37-58, July 1998.
- CARDOZA, R. S.; MERTENS, D. R. Effect of fiber source and content on threshold size for passage and fecal particle distribution. **Journal of Dairy Science**, Champaign, v. 69, p. 134, 1986. Supplement, 1.
- CORRÊIA, C. E. S.; PEREIRA, M. N.; OLIVEIRA, S. G. de; RAMOS, M. H. Performance of Holstein cows fed sugarcane or corn silages of different grain textures. **Scientiae agricola**, Piracicaba, v. 60, n. 4, p. 621-629, Oct./Dec. 2003.
- DADO, R. G.; ALLEN, M. S. Enhanced intake and production of cows offered ensiled alfalfa with higher neutral detergent fiber digestibility. **Journal of Dairy Science**, Savoy, v. 79, n. 3, p. 418-428, Mar. 1996.
- DADO, R. G.; ALLEN, M. S. Variation in and relationships among feeding, chewing and drinking variables for lactating dairy cows. **Journal of Dairy Science**, Champaign, v. 77, n. 1, p. 132-144, Jan. 1994.
- DESWYSEN, A. G.; ELLIS, W. C. Fragmentation and ruminal escape of particles as related to variations in voluntary intake chewing behavior and extent of digestion of potentially digestible NDF in heifers. **Journal of Animal Science**, Champaign, v. 68, n. 11, p. 3871-3079, Nov. 1990.
- DIJKSTRA, J.; FRANCE, J. Comparative evaluation of models of whole rumen function. **Annales de la Zootechnie**, Paris, v. 45, p. 175-192, 1996.
- DIXON, R. M.; MILLIGAN L. P. Removal of digesta components from the rumen of steers determined by sieving techniques and fluid, particulate and microbial markers. **British Journal of Nutrition**, Cambridge. v. 53, n. 2, p. 347-362, Mar. 1985.
- FORBES, J. M. Integration of regulatory signals controlling forage intake in ruminants. **Journal of Animal Science**, Savoy, v. 74, n. 12, p. 3029-3035, Dec. 1996.
- FORBES, J. M.; FRANCE, J. Introduction. In: _____. **Quantitative aspects of ruminant digestion and metabolism**. Wallingford: CAB International, 1993. cap. 1, p. 1-10.
- FRANCE, J.; THORNLEY, H. M.; BEEVER, D. E. A mathematical model of the rumen. **Journal of Agricultural Science**, Cambridge, v. 99, n. 2, p. 343-353, Oct. 1982.

- GILL, M. Modeling nutrient supply and utilization by ruminants. In: GARNSWORTHY, P. C.; COLE, D. J. A. Recent developments in ruminant nutrition. Nottingham: Nottingham University, 1996. v. 3, p. 225-236.
- HUNGATE, R. E. **The rumen and its microbes**. New York: Academic Press, 1966. 533 p.
- ILLIUS, A. W.; ALLEN, M. S. Assessing forage quality using integrated models of intake and digestion by ruminants. In: FAHEY, G. C. **Forage Quality, Evaluation, and Utilization**. Lincoln: University of Nebraska, 1994, cap. 21, p. 869-890.
- ILLIUS, A. W.; GORDON, I. J. Prediction of intake and digestion in ruminants by a model of rumen kinetics integrating animal size and plant characteristics. **Journal of Agricultural Science**, Cambridge, v. 116, n. 1, p. 145-157, Feb. 1991.
- JESSOP, N. S.; ILLIUS, A. W. Modeling the influence of buoyancy on particle dynamics in the foregut of ruminants. In: STONE, G.; FORBES, T. D. A.; STUTH, J. W.; BYERS, F. M. VETERINARY INTERNATIONAL SYMPOSIUM ON THE NUTRITION OF HERBIVORES, 1999, San Antonio, Texas. **Proceedings...** San Antonio, Texas, 1999. p. 10-16. 1 CD-ROM.
- JOHNSON, L. M.; HARRISON, J. H.; DAVIDSON, D.; MAHANNA, W. C.; SHINNERS, K. Corn silage management: effects of hybrid, chop length, and mechanical processing on digestion and energy content. **Journal of Dairy Science**, Savoy, v. 86, n. 1, p. 208-231, Jan. 2003.
- KENNEDY, P. M.; DOYLE, P. T. Particle-size reduction by ruminants: Effects of cell wall composition and structure. In: JUNG, H. G.; BUXTON, R. D.; HATFIELD, R. D.; RALPH, J. **Forage cell wall structure and digestibility**. INTERNATIONAL SYMPOSIUM ON FORAGE CELL WALL STRUCTURE AND DIGESTIBILITY. Madison: American Society of Agronomy, 1993. cap. 20, p. 499-534.
- KENNEDY, P. M.; MURPHY, M. R. The nutritional implications of differential passage of particles through the ruminant alimentary tract. **Nutrition Research Reviews**, Cambridge, v. 1, n. 1, p. 189-208, June 1988.
- KINGSTON-SMITH, A. H.; BOLLARD, A. L.; THOMAS, B. J.; BROOKS, A. E.; THEODOROU, M. K. Nutrient availability during the early stages of colonization of fresh forage by rumen micro-organisms. **New Phytologist**, Local, v. 158, p. 119-130, 2003

- KRAUSE, K. M.; COMBS, D. K.; BEAUCHEMIN, K. A. Effects of Forage Particle Size and Grain Fermentability in Midlactation Cows. I. Milk Production and Diet Digestibility. **Journal of Dairy Science**, Savoy, v. 85, n. 8, p. 1936-1946, Aug. 2002.
- LAREDO, M. A.; MINSON, D. J. The voluntary intake, digestibility, and retention time by sheep of leaf and stem fractions of five grasses. **Australian Journal of Agricultural Research**, Melbourne, v. 24, n. 4, p. 875-888, Nov. 1973.
- LECHNER-DOLL, M.; KASKE, M.; ENGELHARDT, W. Factors affecting the mean retention time of particles in the forestomach of ruminants and camelids. In: TSUDA, J.; SASAKI, Y.; KAWASHIMA R. **Physiological Aspects of Digestion and Metabolism in Ruminants**. London: Academic Press, 1990. p. 455-475.
- LENG, R. A.; PRESTON, T. R. Sugarcane for cattle production: Present constraints, perspectives and research priorities. **Tropical Animal Production**, Santo Domingo, v. 1, n. 1, p. 1-22, 1976.
- MARTZ, F. A.; BELYEA, R. L. Role of particle size and forage quality in digestion and passage by cattle and sheep. **Journal of Dairy Science**, Champaign, v. 69, n. 7, p. 1996-2008, July 1986.
- McLEOD, M. N.; MINSON, D. J. Large particle breakdown by cattle eating ryegrass and alfalfa. **Journal of Animal Science**, Champaign, v. 66, n. 4, p. 992-999, Apr. 1988.
- MENDONÇA, S. S.; CAMPOS, J. M. S.; VALADARES FILHO, S. C.; VALADARES, R. F. D.; LANA, R. de P.; SOARES, C. A.; PINA, D. dos S.; MACHADO, J. C. Cana-de-açúcar como volumoso único para vacas de leite. 3. Consumo e digestibilidade aparente dos nutrientes In: REUNIÃO ANUAL DA SOCIEDADE BRASILEIRA DE ZOOTECNIA, 39., 2002, Recife, PE, **Anais...** Recife : SBZ, 2002. 1 CD ROM.
- MERTENS, D. R.; ELY, L. O. A dynamic model of fiber digestion and passage in the ruminant for evaluating forage quality. **Journal of Animal Science**, Champaign, v. 49, n. 4, p. 1085-1095, Apr. 1979.
- MOORE, L. A. Symposium on forrage utilization: Nutritive value of forage as affected by physical form. Part I. General principles involved with ruminants and affect of feeding pelleted or waffered forage to dairy cattle. **Journal of Animal Science**, Champaign, v. 23, n. 1, p. 230-238, Feb. 1964.
- MURPHY, M. R.; BALDWIN, R. L.; ULYATT, M. J. An update of a dynamic model of ruminant digestion. **Journal of Animal Science**, Champaign, v. 62, n. 5, p. 1412-1422, May 1986.

- MURPHY, M. R.; BALDWIN, R. L.; ULYATT, M. J.; KOONG, L. J. A quantitative analysis of rumination patterns. **Journal of Animal Science**, Champaign, v. 56, n. 5, p. 1236-1240, May 1983.
- OBA, M.; ALLEN, M. S. Evaluation of the Importance of the Digestibility of Neutral Detergent Fiber from Forage: Effects on Dry Matter Intake and Milk Yield of Dairy Cows. **Journal of Dairy Science**, Savoy, v. 82, n. 3, p. 589- 596, Mar. 1999.
- OKINE, E. K.; MATHISON, G. W. Reticular contraction attributes and passage of digesta from the ruminoreticulum in cattle fed roughage diets. **Journal of Animal Science**, Champaign, v. 69, n. 5, p. 2177-2186, May 1991.
- OWENS, F. N.; GOETSCH, A. L. Digesta passage and microbial protein synthesis. In: MILLIGAN, L. P.; GROVUM, W. L.; DOBSON, A. **Control of digestion and metabolism in ruminants**. Englewood Cliffs: Prentice Hall, 1986. p. 196-223.
- POPPI, D. P.; MINSON, D. J.; TERNOUTH, J. H. Studies of cattle and sheep eating leaf and stem fractions of grasses. III The retention time in the rumen of large feed particles. **Australian Journal of Agricultural Research**, Melbourne, v. 32, n. 1, p. 123-137, 1981.
- POPPI, D. P.; NORTON, B. W.; MINSON, D. J.; HENDRICKSEN, R. E. The validity of the critical size theory for particles leaving the rumen. **Journal of Agricultural Science**, Cambridge, v. 94, n. 2, p. 275-280. Apr. 1980.
- RODE, L. M.; SATTER, L. D. Effect of amount and length of forage in diets containing barley or corn on site of digestion and efficiency of rumen microbial protein synthesis. **Canadian Journal of Animal Science**, Ottawa, v. 68, n. 2, p. 445-454, June 1988.
- SAUVANT, D.; BAUMONT, R.; FAVERDIN, P. Development of a Mechanistic Model of Intake and Chewing Activities of Sheep. **Journal of Animal Science**, Savoy, v. 74, n. 11, p. 2785-2802, Nov. 1996.
- SHAVER, R. D.; NYTES, A. J.; SATTER, L. D.; JORGENSEN, N. A. Influence of feed intake, forage physical form, and forage content on particle size of masticated forage, ruminal digesta, and feces of dairy cows. **Journal of Dairy Science**. Champaign, v. 71, n. 6, p. 1566-1572, June 1988.
- STANLEY, T. A.; COCHRAN, R. C.; VANZANT, E. S.; HARMON, D. L.; CORAH, L. R. Periparturient changes in intake, ruminal capacity, and digestive characteristics in beef cows consuming alfalfa hay. **Journal of Animal Science**, Champaign, v. 71, n. 3, p. 788-795, Mar. 1993.

ULYATT, M. J.; DELLOW, D. W.; JOHN, A.; REID, C. S. W.; WAGHORN, G. C. Contribution of chewing during eating and rumination to the clearance of digesta from the ruminoreticulum. In: **Control of digestion and metabolism in ruminants**. Englewood Cliffs: Prentice Hall, 1986. p. 498-515.

VAN SOEST, P. J. **Nutritional ecology of the ruminant**. 2. ed. Ithaca: Cornell University Press, 1994. 476 p.

VAN SOEST, P. J.; SNIFFEN, C. J.; ALLEN, M. S. Rumen dynamics. In: DOBSON, A.; DOBSON, M. J. **Aspects of digestive physiology in ruminants**. Ithaca: Cornell University Press, 1988. p. 21-42.

WALDO, D. R.; SMITH, L. W.; COX, E. L. Model of cellulose disappearance from the rumen. **Journal of Dairy Science**, Champaign, v. 55, n. 1, p. 125-129, Jan. 1972.

WESTON, R. H.; KENNEDY, P. M. Various aspects of reticulorumen digestive function in relation to diet and digesta particle size. In: KENNEDY, P. M. **Techniques in particle size analysis of feed and digesta in ruminants**. Edmonton: Canadian Society of Animal Science, 1984. p. 1-17.

WOODFORD, S. T.; MURPHY, M. R. Dietary alteration of particle breakdown and passage from the rumen in lactating dairy cattle. **Journal of Dairy Science**, Cambridge, v. 71, n. 3, p. 687-696, Mar. 1988.

YANG, W. Z.; BEAUCHEMIN, K. A.; RODE, L. M. Effects of particle size of alfalfa-based dairy cow diets on site and extent of digestion. **Journal of Dairy Science**, Savoy, v. 85, n. 8, p. 1958-1968, Aug. 2002.

**SIMULATION OF RUMEN PARTICLE DYNAMICS USING A MODEL
OF RUMEN DIGESTION AND NUTRIENT AVAILABILITY IN DAIRY
COWS FED SUGARCANE**

RESUMO

COLLAO-SAENZ, Edgar Alain. **Simulação da dinâmica de partículas do alimento no rúmen usando um modelo de digestão ruminal e disponibilidade de nutrientes em vacas em lactação alimentadas com cana-de-açúcar**. Lavras: UFLA, 2004. 66p (Tese de Doutorado em Zootecnia – Área de concentração em Nutrição de Ruminantes).¹

Com o objetivo de simular a disponibilidade de nutrientes como resposta ao padrão de consumo de alimentos, a cinética da redução do tamanho de partícula e a liberação do conteúdo celular, um modelo matemático criado para aperfeiçoar a suplementação de dietas à base de cana-de-açúcar foi adaptado para condições de ingestão descontínua. A inclusão das novas características no modelo original foi realizada no Departamento de Ciência Animal da Universidade de Wageningen nos Países Baixos. A nova versão apresenta um mecanismo de redução de tamanho de partícula e liberação de nutrientes contidos no interior da parede celular para fermentação microbiana. Dois experimentos foram usados para testar o desempenho do modelo em bovinos. Os valores preditos estiveram muito próximos dos valores observados para fluxos de fibra e nitrogênio. O modelo não superestimou ou subestimou as observações experimentais de fluxo duodenal de fibra em detergente neutro (FDN) e nitrogênio não-amoniaco (NNA). A baixa proporção de erro devido a desvio da regressão indica que, a variação dos fluxos reais de NNA e FDN foi reproduzida com precisão pelo modelo. Uma superestimação de 25 e 10% do volume ruminal (V) foi observada em bovinos jovens em consumo alto e baixo, a qual sugere que a equação para determinar o volume ruminal precisa ser adaptada para condições de consumo limitado de alimento. Simulações de produção de leite foram muito próximas de valores observados. A média geral das produções de leite foi predita com precisão. Predições em condições descontínuas de disponibilidade de nutrientes apresentaram maior precisão quando o comportamento real de consumo foi incluído na simulação. O modelo pode ser usado para selecionar estratégias de suplementação de dietas à base de cana-de-açúcar em vacas em lactação.

¹ Comitê Orientador: Paulo César de Aguiar Paiva – UFLA, Jan Dijkstra – WAU, Júlio César Teixeira – UFLA, Juan Ramón Olalquiaga Pérez – UFLA e Pedro Braga Arcuri – EMBRAPA.

ABSTRACT

COLLAO-SAENZ, Edgar Alain. **Simulation of rumen particle dynamics using a model of rumen digestion and nutrient availability in dairy cows fed sugarcane**. Lavras: UFLA, 2004. 66p (Thesis – Doctorate Program in Animal Science. Major – Ruminant Nutrition).¹

In order to simulate nutrient availability as a response of feed intake pattern, of kinetics of particle size reduction and of cell content release, a mathematical model, created to optimize the supplementation of sugarcane based diets, was adapted to non steady-state feeding conditions. The inclusion of the new traits in the original model was accomplished at the Animal Science Department of Wageningen University, The Netherlands. The new version presents a mechanism of particle size reduction and the delay in availability of particles and intracellular contents for microbial fermentation. Two trials were used to test its performance in cattle. In general the predicted values were very close to observed values for fibre and nitrogen flows. The model did not over- or underestimate the experimental observations of duodenal flow of neutral detergent fiber (NDF) and non-ammonia nitrogen (NAN). A very small contribution of the deviation from the regression slope indicates that the variation of observed NDF and NAN flows could be closely reproduced by the model. An overestimation of the rumen volume (V) of 25 and 10 % for low and high intake respectively was observed in steers. This suggests that the equation to determine rumen volume needs to be adapted for low feed intake. Milk production simulations were quite close to observed values. The overall mean was predicted accurately. Predictions in non steady-state conditions showed higher accuracy when real intake behavior was simulated. The model can be used to select strategies of supplementation of dairy cows fed sugarcane based diets.

¹ Guidance Committee: Paulo César de Aguiar Paiva – UFLA, Jan Dijkstra – WAU, Júlio César Teixeira – UFLA, Juan Ramón Olalquiaga Pérez – UFLA e Pedro Braga Arcuri – EMBRAPA.

1 INTRODUCTION

In tropical regions, ruminant production systems are based mainly on forages. Among the tropical forages, sugarcane has a high yield of dry matter (DM) and energy (TDN) per unit area and productivity can reach more than 30 tons of DM per hectare. Sugarcane is usually harvested during the dry season when other fresh forages are not available. Sugarcane does have a high potential in ruminant production because, as observed by Correa et al. (2003), around 30 kg of daily milk production seems to be attainable on diets containing sugarcane as the only forage.

Sugarcane has a high content of soluble carbohydrates, whereas the digestibility of the fiber fraction is low. Leng & Preston (1976) stated that fiber digestibility would not exceed 25%. Laredo & Minson (1973) and Allen (2000) indicated reduction of the voluntary intake by low diet digestibility and low passage rate, and it is therefore assumed that low rates of ruminal digestion and passage may lead to a physical limitation on daily dry matter intake (DMI) that may be achieved. Such a depression in DMI has been observed by Ribeiro et al. (2000) and Correa et al. (2003) in dairy cows fed sugarcane based diets in comparison to maize silage based diets with the same NDF content.

Although no significant effects of chopping and grinding of sugarcane on voluntary DMI were reported by Leng & Preston (1976), other studies suggested a positive effect of a reduction of particle size in poor quality forages with a high cell wall content (Kusmartono et al., 1996). Figueira (1991) concluded that the main limitation of diets based on sugarcane, urea and cotton meal seems to be the high fraction of indigestible fiber of the sugarcane, which affects the intake and performance of the ruminants. Thus, at least in some circumstances, it seems that reduction of the particle size of feeds may contribute to the effects of rumination and thereby to increase DMI.

The degradation rates of intracellular constituents (IC) of forages are normally high, recent research has shown that the IC are not immediately available for microorganisms in the rumen because they are locked up in plant cells that remain total or partially intact after ingestion (Boudon & Peyraud, 2001). For that reason a representation of the release of IC would increase the accuracy of models of rumen function and help to understand the mechanisms involved with the supply of rumen microbes.

With the specific aim to optimize the supplementation of sugarcane based diets and to evaluate the effects on milk production, Dijkstra et al. (1996a) developed a mechanistic model of rumen digestion of sugarcane-based diets for dairy cows. The primary objective of that model was to indicate pre-experimentally which combinations of locally available supplements could enhance performance on sugarcane-based diets and to prevent unnecessary feeding trials. However, the model did not represent a mechanism of particle size reduction and delay in availability of particles and IC for microbial fermentation or patterns of feed intake.

The objective of the present study is to extend the model of Dijkstra et al. (1996a) to non steady-state feeding conditions and to enable the model to simulate nutrient availability as a response to feed intake pattern, kinetics of particle size reduction and cell content release. The extended model may help in particular to explain the effects of variation in the physical and chemical characteristics of tropical feeds on observed milk yields.

2 MATERIAL AND METHODS

The inclusion of the new traits in the model developed by Dijkstra et al. (1996a) had been accomplished at the Animal Science Department of Wageningen Agricultural University. The equations that constitute the model and general notation used are listed in the Appendix. The model was run using the simulation program SMART® developed by the Wageningen Agricultural University.

Model modifications

Particle size reduction

In the original model a constant feed intake during the day was assumed and the rumen contents were physically distinguished into particle and fluid fraction. The model included 11 state variables. Undegradable fiber (Fu), degradable fiber (Fd), insoluble starch (Si) and soluble starch and sugars (Sc) represent the carbohydrate fractions in the rumen. Nitrogen-containing fractions include undegradable protein (Pu), insoluble and degradable protein (Pd), soluble protein (Ps) and ammonia (Am). Fatty acid fractions include long chain fatty acids (Ld) and volatile fatty acids (Va) and, the rumen microbial DM (Mi) is represented by one state variable. Detailed description of the model development and applications are described in Dijkstra et al. (1996a) and Dijkstra et al. (1996b). The equations that constitute the original model are listed in the Appendix.

To include the effect of particle size reduction in the model description, a new state variable for large particles (QLp) was added to the original 11 state variables, and was defined by Eq. [1a]. The concept with a single aggregate large particle (LP) pool comprising all the insoluble components in the diet, except insoluble starch (Si), corresponds to that proposed by Baldwin et al. (1987). A small particle (QSp) zero pool (meaning it is calculated from other

pool sizes and flux rates equations) was introduced as the sum of insoluble nutrients in small particle form which is directly susceptible to microbial degradation (Eq. [1i]): degradable fiber (QFd), undegradable fiber (QFu), insoluble but degradable protein (QPd) and undegradable protein (QPu) and QSi. The conversion of QLp to QSp was totally dependent upon rumination and was represented as a function of the physical properties of feeds (comminution rate) and the time spent ruminating (Baldwin et al., 1987) (Eq. [1h]).

Quantity of Rumen Large particles (QLp, g):

$$dQLp/dt \text{ (g/h)} = PLpILp - ULpLSp \quad [1a]$$

Lp uptake with feed (gLp/h):

$$PLpILp \text{ (g/h)} = DLp \quad [1b]$$

$$DLp \text{ (g/h)} = (DFu + DFd + DPu + DPd) * (1 - FSp) \quad [1c]$$

$$DFu = \text{feed} * \text{frfu} / 1000. \quad [1d]$$

$$DFd = \text{feed} * \text{frfd} / 1000. \quad [1e]$$

$$DPu = \text{feed} * \text{frpu} / 1000. \quad [1f]$$

$$DPd = \text{feed} * \text{frpd} / 1000. \quad [1g]$$

Feed is the quantity of feed ingested per day (g/d)

FrFu, FrFd, FrPu, FrPd are the fractions of undegradable NDF, degradable NDF, undegradable protein and degradable protein in the feed (g/kg DM).

FSp is the fraction of small particles in feed

Conversion to small particles (g of Lp/h):

$$ULpLSp = kLpSp * \text{Rum} * QLp \quad [1h]$$

kLpSp is the fractional comminution rate (/h)

A comminution rate or rate to conversion to small particles (kLpSp), of 0.09/h (2.2/d) was used because of the low degradability of sugarcane. A value of 4.5/d was proposed by Bannink & De Visser (1997) because of the high

degradability of the fresh perennial ryegrass in the diets evaluated by them. Rum is the proportion of time spent ruminating during the day (fraction of the day). Baldwin (1995) proposed Rum = 0.33 in continuous feeding. A chewing time of 54 min/kg DM was estimated for 7.5 kg DM intake. Therefore, the Rum parameter was calculated as 0.28 ((7.5 x 54/60)/24). Lignification, DMI, stage of maturity, protein content, and many other features intrinsic to the plant may affect these figures.

Quantity of Rumen Small Particles (QSp, g):

$$QSp \text{ (g/h)} = QSi + QFu + QFd + QPu + QPd \quad [1i]$$

Description of QFd, QFu, QPd, QPu is similar to original model

Quantity of rumen insoluble starch (Qsi, g)

$$dQSi/dt \text{ (g/h)} = PSiISi - USiSSc - USiSEx \quad [1j]$$

Uptake of Si with feed (g Si/h)

PSiISi = Dsi, corresponding to original model

Quantity of rumen undegradable fiber (QFu, g)

$$dQFu/dt \text{ (g/h)} = PFuIFu + PFuLSp - UfuFEx \quad [1k]$$

Uptake of Fu small particle with feed (g Fu/h)

$$PFuIFu = DPu * FSp \quad [1l]$$

Reduction of particles size of large particle Fu (g Fu/h)

$$PFuLSp = ULpLSp * FFLpFu \quad [1m]$$

Fraction of Fu large particles with feed

$$FFLpFu = DFu * (1 - FSp) / DLp \quad [1n]$$

Outflow of Fu from rumen (g Fu/h)

UfuFEx same as in original model

Same for rumen undegradable protein (QPu, g)

Quantity of rumen degradable fiber (QFd, g)

$$dQFd/dt \text{ (g/h)} = PFdIFd + PFdLSp - UFdFSc - UFdFEx \quad [10]$$

Same for rumen degradable protein (QPd, g)

Dry matter intake

The steady-state simulation (constant feed intake during the day) with the original model was changed into intake of two separate meals per day adapting the work of Miranda et al. (1999). They observed an average number of 12 meals per day in crossbred heifers Holstein X Zebu receiving sugarcane + urea based diets supplemented with 15 % of cotton meal. The experiment showed that 85 % of ingestion occurred during the first 12 hours after the unique supply of feed per day, probably, because the offer of fresh diet promotes higher DMI. This ingestive behavior was used to simulate the consumption of 85 % in the first six hours and 15 % the next six hours every 12 hours when the diet is supplied twice in a day.

Because in non steady-state conditions fluxes continuously vary with time, fluxes had to be integrated during the last 24 hours for calculations of model outcomes. The integration step was reduced to 0.01h to ensure that with pulses of feed intake accurate integration results will be obtained. Otherwise, the abrupt changes in pools of small size would easily become exaggerated and lead to unreliable results of the whole model outcome.

Microbial death

A Michaelis-Menten equation had to be introduced to account for the death of microorganisms (UMiMd; Eq. [2a]) in absence of substrate and to reduce the nutrient utilization efficiency of microbial dry matter (Mi). Otherwise, in non steady-state conditions such as with the simulation of one or two meals for a few hours during the day, for some state variables unrealistic negative values would be obtained. The death of microorganisms resulting from this equation was distributed as a new input of the pools of nutrients according to the composition of microbial matter used by Dijkstra et al. (1996a).

The average maximum relative death of microbial in the absence of substrate (Vmaxd) was defined as 0.4 /h considering the average maximum relative growth *in vitro* of 0.8/h described by Russell & Baldwin (1978), when preformed monomers were supplied. A very small inhibition constant of Sc to Mi (JScMi) was arbitrarily set at 0.001 g/l based on some preliminary runs and the desire to avoid negative values of the Sc pool, the value of JScMi.

Quantity of Rumen microbial mass (Q Mi, g):

$$dQ_{Mi}/dt \text{ (g/h)} = P_{Mi}A_{Mi} + P_{Mi}P_{Mi} - U_{Mi}M_{Ex} - U_{Mi}M_d \quad [2a]$$

Rate of death of the microbial mass (g Mi/h)

$$U_{Mi}M_d \text{ (g/h)} = (V_{maxd} * Q_{Mi}) / (1 + (C_{Sca} / J_{ScMi})) \quad [2b]$$

C_{Sca} is the concentration of soluble starch and sugar in the rumen (g Sc/l)

$$= Q_{Sa} / \text{Rumen Volume}$$

P_{Mi}A_{Mi}, P_{Mi}P_{Mi}, U_{Mi}M_{Ex} similar to original model

Salivary nitrogen

Non-dietary N inflow is simulated by quantification of the ammonia production from urea transported across the rumen wall and of the saliva production. To simulate discontinuous feed intake, original equations had to be changed into a constant parameter.

Urea transfer to Am (g Am/h):

$$P_{AmUAm} = v_{UrAm} * D_{NiCt} / (1 + C_{Am} / J_{AmUAm}) \quad [3a]$$

v_{UrAm} is the maximum amount of urea recycled per dietary N (g urea/ g N);
 D_{NiCt} is the diet dependent inflow rate of Ammonia (g Am/h) and it is calculated from the N content of the diet.

C_{Am} (= Q_{Am} / Rumen Volume) is the concentration of Am (g Am/l)

J_{AmUAm} is the inhibition constant of Am in plasma urea to rumen Am (g Am/l)

Rumen volume

To simulate non-constant feed intake, the volume of rumen fluid (V) changed from a constant parameter value in the original model into a variable dependent on the size of the meals and dry matter content of the diet. A non-linear relationship between DM percentage of the rumen contents (DMC) and the DM rumen pool size (DMRP) was adopted (Eqs. [4a] & [4b]), according to the equation proposed by Chilibroste et al. (2001). This relationship allowed V to vary during the day according with rumen DM content:

DM percentage of rumen contents:

$$DMC = 12.05 (\pm 0.19) \times (1 - e^{-0.32(\pm 0.17) \times DMRP}) \quad [4a]$$

DM percentage of rumen content (DMC, %)

DM rumen pool size (DMRP, kg) calculated as the sum of all the pools in the rumen.

$$V = (100 * DMRP / DMC - DMRP) / 1000 \quad [4b]$$

Cell content release

In order to account for the delay in IC release, two new state variables were introduced which represent the pools of soluble protein (QP_{su}) and soluble starch and sugars (QSc_u) not immediately available for microbial utilization. Both pools received a fraction of the DMI, dependent on the particle size. It is assumed that IC's in the large particles fraction (FL_p) need to be released before microbial utilization [5a, 5b, 6a and 6b] and IC's in FSp are immediately available for fermentation [5c and 6c].

The unique output of each pool was the release of nutrients to the two pools of nutrients directly available for microbial utilization, P_{sa} and S_{ca}, which fully correspond to those in the original model. The release of the soluble nutrients was related to the time spent eating + ruminating (R_{um}) and fractional release rates of Sc_u and Ps_u to the available pools following the experiment of Boudon et al. (2002). They observed that more than 85% were released after 3 hours and all soluble carbohydrates disappeared from fresh rye grass 6 hours after the meal. The fractional release rate of Sc (kSc_uS_{ca} = 1.8/h) used in the model allowed 78 % after 3 hours and more than 95% of Sc_u release 6 hours after the meal. The release of N compounds was estimated as being 45% after 3 hours and 90% after 6 hours (Boudon et al., 2002). The fractional release rate of Ps (KPs_uP_{sa} = 1.2/h) predicted a disappearance of 87% from the PS_u pool after 6 hours.

The quantities of soluble starch and sugars (dQSc_a/dt) and soluble protein (dQP_{sa}/dt) available for fermentation are changed as well. The driving variables (inputs) were DS_{ca} and DP_{sa} respectively, and they had an additional input, the release of soluble starch and sugars (USc_uS_{ca} for dQSc_a/dt) and soluble protein (UPS_uPS_a for dQP_{sa}/dt), in comparison with the original model.

Quantity of soluble starch and sugars unavailable for fermentation (QScu, g Scu):

$$dQ_{Scu}/dt = P_{ScI}Scu - U_{Scu}Scu \quad [5a]$$

$P_{ScI}Scu = D_{Scu}$: uptake of Sc unavailable for the microbes with feed (g Sc/h)

$$D_{Scu} = \text{feed} * \text{frsc}/1000 * (1 - F_{Sp}) \quad [5b]$$

$$D_{Sca} = \text{feed} * \text{frsc}/1000 * F_{Sp} \quad [5c]$$

$U_{Scu}Scu$ is the Sc release from unavailable Sc pool (g Scu/h)

$$= Q_{Scu} * K_{Scu}Scu * R_{um}$$

Quantity of soluble protein unavailable for fermentation (QPsu, g Psu):

$$dQ_{Psu}/dt = P_{PsI}Psu - U_{Psu}Psu \quad [6a]$$

$P_{PsI}Psu = D_{Psu}$: uptake of Ps unavailable for the microbes with feed (g Ps/h)

$$D_{Psu} = \text{feed} * \text{frps}/1000 * (1 - F_{Sp}) \quad [6b]$$

$$D_{Psa} = \text{feed} * \text{frps}/1000 * F_{Sp} \quad [6c]$$

$U_{Psu}Psu$ is the Ps release from unavailable Ps pool (g Psu/h)

$$= Q_{Psu} * K_{Psu}Psu * R_{um}$$

Application of the model

Sensitivity analysis

To examine the effects of rate of comminution (k_{LpSp}), fractional release rate of soluble starch and sugars ($K_{Scu}Scu$) and soluble protein ($k_{Psu}Psu$), small particle size fraction (F_{Sp}), rumination and mastication times (R_{um}), inhibition of nutrient utilization (J_{ScMi}), velocity of death and utilization of soluble starch and sugars by microbial mass (V_{MaxD} and V_{ScMi}), a sensitivity analysis was performed to ensure that the sensitivity of the model outputs are appropriated to the parameters included as inputs.

For the simulations, a pattern ration with 60% of small particles was considered, and for this percentage Rum of 0.28 was used considering an intake of 7.5 kg DM/day. To simulate real conditions, these values must be changed together to account for different quantities of DMI or FSp. However, to test the specific sensitivity of each one, the parameters were considered independent and changed one by one in order to test their effect on the simulated results of the type and quantity of nutrients absorbed and potential milk yields.

The same diets for a Holstein X Zebu cow with live weight of 470 kg as evaluated by Dijkstra et al. (1996a) were used in the present study. The first diet had 10 g of urea/ kg of fresh sugarcane (Diet C). In the second diet, 20% of the sugarcane/urea mix was replaced by maize grain (Diet CM). The nutrients present in 7.5 kg of DMI were 3210 g and 3675 (g/day) of starch and soluble sugars for diet C and CM respectively. Total nitrogen and non-urea nitrogen were 152 g/day and 22 g/day for diet C and, 141 g/day and 37 g/day for diet CM. NDF was 3525 and 2985 (g/day) respectively for diets C and CM. Long chain fatty acids (LCFA) was set as 58 g/day for diet C and 98 g/day for diet CM.

The parameters were set at 0.5, 0.75, 1.0, 1.25 and 1.5 times their values and tested in steady-state and non steady-state conditions. In the latter, a new meal of two hours duration was simulated every 12 hours. Thus, for every diet parameter combination, five steady-state and five non steady-state solutions were obtained.

Comparison between simulated and experimental values.

Two experiments were used to evaluate model performance. Even though a lot of information in sugarcane based diets for ruminants exists, it is difficult to find data sets providing adequate information on nutrient supply and

complete profile of nutrients for absorption to allow a full comparison between predicted and observed values.

The first experiment was performed by Matos (1991) using crossbred (*B. Taurus x B. indicus*) growing steers (290 kg average LW) in factorial design with two levels of DMI (52.5 g DM/ kg^{0.75} LW and 78.75 g DM/ kg^{0.75} LW) and two levels of urea inclusion (10 or 15 g/kg fresh sugarcane weight) in chopped sugarcane supplemented with rice meal (210 g/ kg DM diet). Average DMI for the four diets were 3.7; 5.4; 3.5 and 5.3 kg DM/d. Crude protein of the two diets according of urea levels were 14.45 % and 19.7 for 1 and 1.5 % of urea inclusion respectively. Percentage of NDF, ADF, soluble carbohydrates and starch were almost the same in both diets. The observed values for neutral detergent fibre (NDF) and non-ammonia nitrogen (NAN) rumen outflows and, apparent rumen degradation of starch and sugars (fraction of starch and sugar intake) were compared with predicted values by the model.

The effect of supplementation of sugarcane based diets with soybean meal and whole soybean on milk production was reported by Assis et al. (1999). They fed 32 dairy cows consuming an average of 11.4 kg DM with four sugarcane and urea based rations supplemented with 1.6 kg DM/cow/day of soybean meal (SM); 1.6 and 3.2 kg DM/cow/day of whole soybeans (1.6WS and 3.2WS respectively) and; 3.1 kg DM/cow/day of a mix with 2.1 kg DM whole soybeans and 1.0 kg DM ground corn (WSM). The observed values were used to test the accuracy of the milk production predictions under non steady-state conditions.

Evaluation of prediction results

In both experiments, the mean square prediction error (MSPE) was used to indicate the error of predicted values relative to actual values.

$$\text{MSPE} = \sum_{i=1}^n (O_i - P_i)^2 / n$$

Where, O_i and P_i are the observed and predicted values; $i = 1, 2, \dots, n$; n is the number of experimental observations. The MSPE is decomposed into error due the overall bias of prediction (i), error due to deviation of the regression slope from one (ii), and the error due to disturbance proportion (iii) (Bibby & Toutenburg, 1977). According to Gerrits (1996), (i) represents the proportion of MSPE, due to a consistent over or underestimation of the experimental observations by model predictions. (ii) Represents the proportion of MSPE, due to inadequate simulation of differences between experimental observations. Finally, (iii) is the fraction unrelated to the errors of model prediction.

3 RESULTS AND DISCUSSION

Inclusion of new features attempting to increase the accuracy of the simulations usually carries new problems of parameterization and befuddles the performance. The present model includes more detailed characterization of particle kinetics and cell content release in non steady-state conditions than the model described by Dijkstra et al. (1996a).

In steady-state conditions (constant rate of feed intake) the inclusion of a mechanism of particle size reduction showed exactly the same results as obtained with the original model, even with varying small particle fractions (FSp) and fractional rates of comminution (kLpSp and Rum). This result has to be expected because under steady-state conditions the sum of inflows to degradable substrate pools in the extended version of the model must remain the same to that in the original model. Outflow from the Lp pool equaled the inflow to it, and outflow from the Lp pool and from the diet contributes for 100% to inflow for the Sp pool. In contrast to the result obtained with steady-state conditions, in non steady-state conditions with varying patterns of feed intake, the inclusion of a mechanism of particle size reduction did affect the availability of nutrients for microbial use in the rumen and consequently resulted in changes in the fluxes and potential milk yields simulated.

Supplementation with corn increased all the absorbed nutrients at different fractional release rates of Sc and Ps. According to Boudon & Peyraud (2001), degradation rate of soluble carbohydrates or nitrogen compounds of the IC can have an important impact on the nature of the nutrient supplied to the animal. Inclusion of variables to account for these effects seems to get better availability of substrates for Mi, especially in diets with long fast periods. The original model did not need to represent these effects because it assumed continuous input of nutrients.

In the same way, the microbial death rate was diminished with corn supplementation. The microbial death variable depends on nutrient availability and an extra source of glucose for the Mi diminished the critic time with small Sc pool sizes leading to microbial death. To alter the representation of rumen volume (V) promoted the necessity to change the assumption that fractional passage rates could be represented by a constant figure. Intake during few hours caused variation in V and for this reason passage rates were dependent on the pool sizes.

The response of the model was as expected. Supplementation with corn increased the quantity of nutrients absorbed in the intestine. This behavior was already observed in the original model. Simulation of non steady-state conditions with intake of two meals during two hours per meal led at certain moments during the day to very small values for the rumen pool sizes (some moments with less of one gram of soluble carbohydrates) although simulations of daily digestion, passage and milk production still remained reliable in most cases. The use of the ingestive behavior observations from Miranda et al. (1999) as an input to the model, allowed longer availability of nutrients and increased the accuracy of the simulations due to diminished microbial death rates. In simulations of sheep fed alfalfa diets once daily in a three to four hours meal, Murphy et al. (1986) predicted faster ruminal digestion and passage than the ones observed, resulting in smaller pool sizes before feeding. They also reported aberrant model behavior when diets of very low quality were used. Therefore, they concluded that the rates of particle size reduction were not sufficient to maintain fermentation, microbial growth and passage from the rumen in their non steady-state simulations.

Supplementation of sugarcane with corn (Diet CM) raised the absorption in the intestine of all the nutrients. Absorbed amino acids were approximately 25% higher than with the unsupplemented diet. Inclusion of starch delivered

more fermentable organic matter and promoted higher yield and outflow of microbial mass to the intestine. Quantity and type of carbohydrates fed directly affects microbial protein production and amino acid supply and hence may affect milk protein synthesis (Mertens, 1999). Glucose absorption was increased by corn supplementation because a variable proportion of dietary starch escapes rumen fermentation and is subsequently subjected to enzymatic digestion in the small intestine (Nocek & Tamminga, 1991). The absorption of long chain fatty acids (Li) was almost doubled because of the higher content of Li of the corn when compared with the original diet of sugarcane and urea and, microbial lipids also contributed to absorbed Li. Inclusion of corn grain did not affect significantly the absorption of volatile fatty acids (AVf) maybe due to the relatively high total values of AVf in the rumen and other organs for sugarcane diets reported by Leng & Preston (1976).

Substitution of 20% of sugarcane with corn also diminished the rumen volume. Because of the rapid fermentation of its organic matter, corn allows faster clearance from the rumen than the matter of sugarcane. Sugarcane fiber occupies space in the rumen and requires more time to be chewed and reduced before escape from the rumen.

Sensitivity analysis

The standard estimates of absorbed amino acids, glucose, lipids, volatile fatty acids and the rumen volume for the two diets are shown in the Table 1. The sensitivity of the eight parameters after changing their assigned values at 0.5, 0.75, 1.0, 1.25 and 1.5 times are given in Table 2.

Table 1. Standard estimates for absorbed amino acids (Aaa), glucose (AGI), long chain fatty acids (ALi) and volatile fatty acids (AVf) from gastrointestinal tract and rumen volume (V) on sugarcane with urea diet (C) or sugarcane with urea and corn grain diet (CM) calculated by the model¹.

	Aaa		AGI		ALi		AVf		V	
	g/d		g/d		g/d		mol/d		l	
	C	CM	C	CM	C	CM	C	CM	C	CM
STST	337.7	420.6	257.3	416.2	60.0	96.6	39.3	44.6	62.6	60.1
NSTST	216.0	319.5	390.0	501.9	76.0	108.5	37.0	43.0	63.6	60.1

¹Abbreviations used: STST, steady-state conditions; NSTST non steady-state conditions.

Table 2. Average slope of regression line for absorbed amino acids (Aaa), glucose (AGI), long chain fatty acids (ALi) and volatile fatty acids (AVf) from gastrointestinal tract and rumen volume (V) on sugarcane with urea diet (C) or sugarcane with urea and corn grain diet (CM) calculated by the model, obtained by perturbing selected parameter in turn¹.

Perturbed parameter	Aaa g/d		AGI g/d		ALi g/d		AVf mol/d		V l	
	C	CM	C	CM	C	CM	C	CM	C	CM
kLpSp STST	16.9	12.9	-21.7	-29.8	0.4	0.5	2.3	2.4	-21.1	-18.6
kLpSp NSTST	10.9	19.0	-80.8	-62.1	-0.3	-1.0	3.3	3.5	-21.2	-19.0
Rum STST	17.7	13.6	-22.8	-31.3	0.4	0.5	2.4	2.6	-22.1	-19.6
Rum NSTST	-40.3	-37.5	55.6	11.1	7.8	6.2	0.5	1.8	-21.4	-19.1
FSp STST	21.7	10.5	-25.5	-35.8	0.5	0.4	2.9	3.2	-25.5	-22.3
FSp NSTST	-15.6	-10.5	21.5	-12.5	3.8	3.5	1.9	2.0	-24.9	-22.4
Vmaxd STST	-1.8	-2.3	-0.7	-0.7	0.4	0.6	0.0	0.0	0.0	0.0
Vmaxd NSTST	-2.1	-5.4	3.3	3.4	0.4	0.8	-0.1	-0.1	0.0	0.1
JScMi STST	-1.8	-2.3	-0.8	-0.7	0.4	0.6	0.0	0.0	0.0	0.0
JScMi NSTST	-1.8	-4.9	2.6	3.4	0.3	0.7	-0.1	-0.1	0.0	0.1
vScMi STST	-126.8	-277.0	-116.9	-88.8	-2.8	-8.0	0.6	2.6	-0.8	-1.0
vScMi NSTST	-192.0	-239.4	183.8	94.8	12.4	11.7	-5.7	-4.8	1.7	2.1
kScuSca STST	0.8	0.7	-0.9	-1.6	0.0	0.0	0.1	0.1	-0.9	-0.9
kScuSca NSTST	-59.3	-59.8	149.7	68.3	8.6	6.6	-2.5	-1.3	0.0	-0.1
kPsuPsa STST	0.0	0.0	0.0	-0.1	0.0	0.0	0.0	0.0	0.0	0.0
kPsuPsa NSTST	1.0	1.0	-5.2	-3.9	0.2	0.3	0.1	0.0	-0.1	-0.1

¹ Abbreviations used: STST, steady-state conditions; NSTST, non steady-state conditions; kLpSp, Fractional comminution rate; FSp, Fraction of small particles in feed; Rum, ruminating factor; Vmaxd, average maximum death rate of microorganisms; JScMi, Inhibition constant of utilization of soluble starch and sugars by the microbial mass; VScMi, Maximum rate of utilization of soluble starch and sugars for microbial mass maintenance; kScuSca, Fractional release rate of soluble starch and sugars; kPsuPsa, Fractional release rate of soluble protein

As commented before, particle size reduction affected the model mainly under non steady-state conditions (NSTST). The differences observed for steady-state simulations (STST) were due to changes on V because V is an auxiliary variable which depends on the DM content of the rumen. STST will not be affected if V and flows do not change along the day. The variation in V affects in principle all fluxes and ruminal concentrations of the nutrients and micro-organisms.

Increase of the particle size reduction by rumination (kLpSp) had moderate effects on Aaa and AGI, both with NSTST and STST. Variations observed under STST conditions were due model adjusts of rumen volume. These results correspond to values obtained by Baldwin et al. (1987). They reported that changing the kLpSp has quite significant effects upon the size of the LP pool but only moderate effects upon predicted digestibility. A higher comminution rate slightly increased the absorption of amino acids. The protein in small particles is likely to be degraded more rapidly than the protein in large particles because of the larger surface area of small particles (Dhiman et al., 1997). In diets with highly rumen degradable protein this can increase the microbial efficiency and, in presence of adequate carbohydrate fractions, may allow more microbial protein flowing to be absorbed in the intestine. On the other hand, a faster reduction of sugarcane and corn particles increased the rumen fermentation of non fiber carbohydrates leading to a diminished quantity of starch or sucrose flowing to the intestine and, therefore, a decrease in the absorption of glucose. Higher values of kLpSp decrease the V, an effect which was confirmed by Allen & Mertens (1988). They stated that fiber digestibility decreases as rate of passage increases and, rate of passage is inversely related to rumen volume at a given level of intake. According to Baldwin (1995), several questions concerning kLpSp remain unresolved at present; whether kLpSp should be a function of the physical properties of feeds, or a function of

fermentation rate, and whether the time needed for the ingested feeds to become hydrated puts a delay on the availability of feeds for microbial degradation.

As mentioned above, some of the parameters tested in the sensitivity analysis are dependent on others. This means that with actual simulation studies these parameters probably need to be changed together to ensure a reliable performance of the model. The fraction of small particles (FSp), for example, should affect also the time spend ruminating (Rum).

Eq. [1h] showed that Rum and kLpSp have direct relation to determine the output of Lp pool and should have same sensitivity as observed for STST. However, in NSTST, the sensitivities of both parameters were different. The differences in quantities of absorbed nutrients were due to differences in microbial population. Eq. [2a] and [2b] control microbial excess of nutrients utilization and a small soluble nutrient pool led to increased microbial death, since the Rum parameter is also related to fractional release rate of Psu and Scu. Small Rum values diminished the release of IC's, allowed more constant quantities of soluble nutrients for the micro-organisms and decreased the microbial death.

The model showed highest sensitivity to the amount of soluble starch and sugars (Sc) used by the microorganisms for maintenance (vScMi). This parameter was defined as 0.08 g Sc/ g Mi/h according to the maintenance values obtained by Russell & Baldwin (1979) which varied from 0.022 to 0.187 g Sc/ g Mi/h for a number of bacterial species. The model outcomes deviated most when this value was reduced to 0.04, which shows the importance of a careful estimate of these parameters related to microbial metabolism. This finding corresponds to the judgment of Dijkstra & France (1995) that the representation of metabolic activity of rumen microbes and the chances of survival of individual species in whole rumen models deserves special attention in order to obtain accurate estimates of nutrients available for absorption.

The absorption of nutrients did not present sensitivity to changes of V_{maxd} and J_{scMi} because these parameters act in critical conditions to regulate an excess of utilization of Sc by Mi and avoid negative values for some pools. The small sensitivity shows that its regulation functions are working appropriately.

Finally, the release rate of soluble sugars and starch from ingested feed was highly sensitive under non steady-state conditions. The decrease of absorption of amino acids can be explained by a reduced outflow of microbial protein to the intestine. A fast liberation of soluble carbohydrates from diets with fasting periods of 10 hours, would lead to a long period without substrates which affects apparent bacterial yield due to a lack of carbon skeletons and availability of energy (ATP) for protein synthesis for more prolonged periods, leading to more microbial death. The decrease in the microbial population diminished the utilization of Sc for microbial growth and therefore allowed a higher escape from the rumen, increasing the quantity of Sc absorbed in the intestine.

Fractional release rate of soluble protein did not affect the absorption of nutrients in any situation. This effect is maybe due the small quantity of soluble protein in both C and CM diets. Diets with a higher crude protein content also did not have a large effect on absorbed nutrients. According to Boudon & Peyraud (2001) the degradation rate of nitrogenous compounds is smaller than the degradation rate of free sugar and (part of) starch. In addition it ranges from 4 to 47 %/h for the protein fraction, and 200 %/h for intracellular non protein nitrogen. They also found that a large part of foliar proteins is far less easily released during ingestive mastication than free sugars and non protein nitrogenous compounds. The fractional release rate used for IC nitrogen was 30% smaller than the fractional release rate of Sc. Therefore, simulated available nitrogen pool, as a substrate for micro-organisms, did not decrease as fast as the

soluble sugars pool. In consequence, different release rates of soluble protein did not have major effects on diets supplemented with urea.

Comparison between observed and predicted values

The model was tested with independent observations for growing cattle (Matos, 1991) and dairy cows (Assis et al., 1999).

Nutrient outflows and apparent rumen digestion.

For growing cattle, a comparison was made between predicted and observed values of duodenal flow of neutral detergent fiber (NDF; Figure 1) and non-ammonia nitrogen (NAN; Figure 2) rumen outflows and of apparent rumen digestion of starch and sugars (Figure 3).

Individual simulations of NDF outflows were quite close to observed values (Figure 1) with a root MSPE of 14.2% of observed mean. Ninety-one percent of MSPE was attributed to the random disturbance proportion, 7.45% to the overall bias and 1.33% to the deviation of the regression slope from one. The model did not over- or underestimated the experimental observations. The very small contribution of the deviation of the regression slope indicates that the variation of observed NDF flows could be closely reproduced by the model. This means that the mechanisms of fibrolytic activity in the rumen seems to be represented well by the model, which corresponds to the conclusions drawn by Neal et al. (1992) on a similar rumen model that was based on the same principles of that used in the present study. Supplementation with urea slightly increased (0.6 and 1.4% for the same level intakes) simulated rumen fibre degradation (Table 3). This difference was not apparent statistically for the actual values (Matos, 1991).

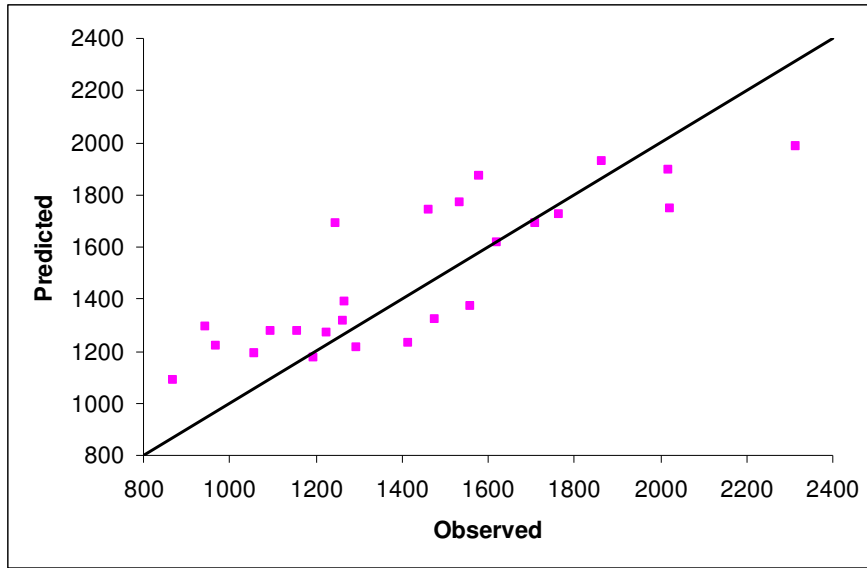

Figure 1. Comparison of observed and predicted rate of NDF outflow from the rumen (g/d).

Table 3. Predicted and observed means of NDF and NAN rumen outflow (g/d) and apparent rumen degradation of starch and sugars (%) of different levels of intake and urea inclusion¹.

	LI	HI	LU	HU
NDF outflow				
Matos (1991)	1163.3	1689.6	1440.9	1433.4
Predicted	1239.8	1726.2	1526.7	1461.4
NAN outflow				
Matos (1991)	47.5	62.4	55.8	54.7
Predicted	43.2	63.5	52.3	52.4
NAN outflow				
Matos (1991)	91.1	90.7	90.5	91.2
Predicted	89.06	89.9	89.2	89.7

¹LI, low intake; HI, high intake; LU, 10g of urea/kg fresh sugarcane; HU, 15g of urea/kg fresh sugarcane.

Also the predicted NAN flows are in general agreement with observed values (Figure 2). Both observed and predicted values of NAN flow to the duodenum were lower than the rate of N ingestion with feed. The root MSPE represented 8.5 g, i.e., 15.3% of observed mean. The contribution of the random variation to the MSPE was 91.7 %. The proportions of overall bias and deviation of the slope to unity represented 3.0 and 5.6 % respectively. The model simulated precisely the effect of increasing intake on rumen NAN outflow. Matos (1991) found effects ($P < 0.05$) on NAN outflow due to the level of ingestion with 45.8 g/d and 63.1 g/d for low and high intakes, whereas the average means of predicted values for both levels were 43.2 and 63.7 g/d. An increased level of dietary urea from 1 to 1.5% in a sugarcane based diet supplemented with rice meal did not affect predicted outflow rate of NAN (52.3 and 51.7 g/d), which corresponds to the observations by Matos (1991) who also could not establish an effect (56.8 and 53.0 g/d). Mendonça et al. (2002)

affirmed that apparent digestibility of dry matter, organic matter, crude protein and total carbohydrates were not influenced by the different levels of urea on sugarcane diets. Pate et al. (1985), however, reported an increased ($P < 0.01$) digestibility of crude protein with an increase in dietary urea levels in sugarcane diets supplemented with urea-corn meal and cottonseed meal. They explained this fact by the complete hydrolysis of urea to ammonia and subsequent use by bacteria or absorption of ammonia from the rumen. Although the urea inclusion in other experiments should have the same effect, the high level of urea inclusion (up to 56 % of dietary nitrogen as urea) used by Pate et al. (1985) could cause the increase on the protein digestibility.

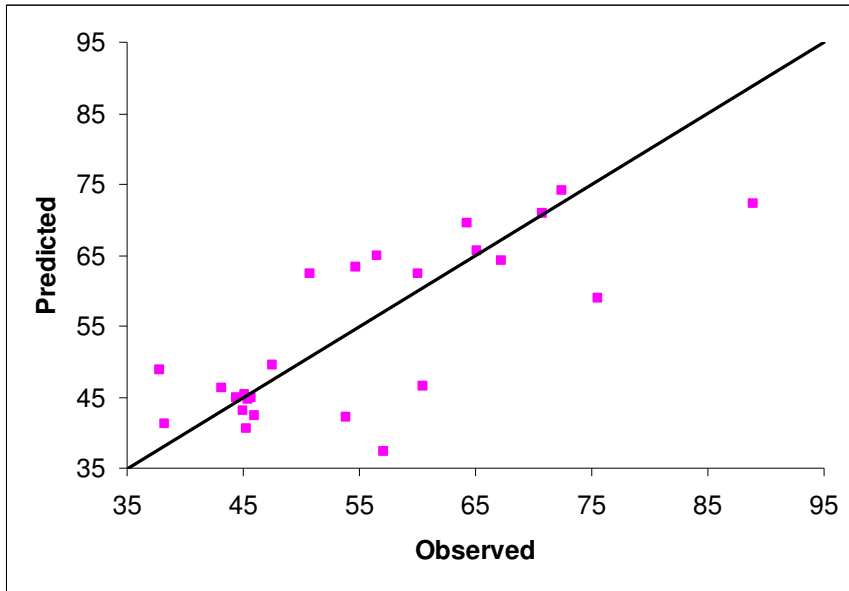

Figure 2. Comparison of observed and predicted rate of NAN outflow from the rumen (g/d).

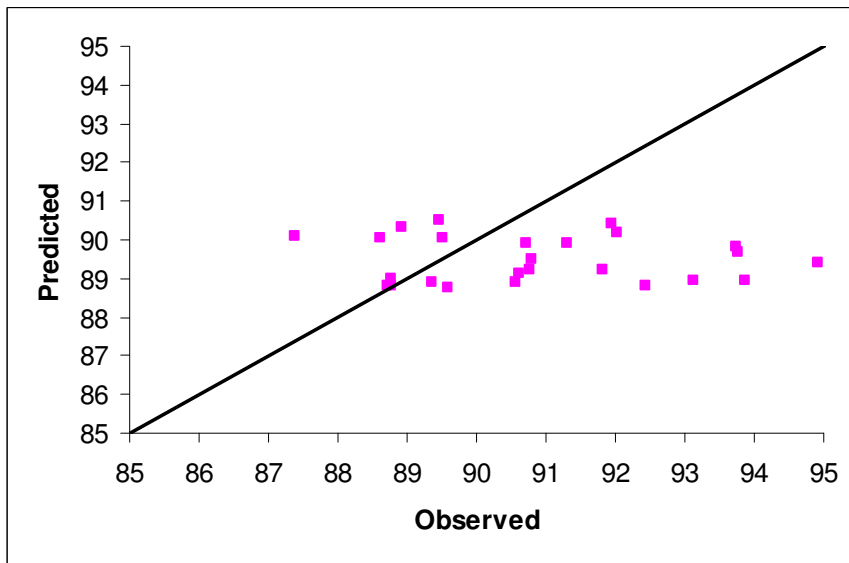

Figure 3. Comparison of observed and predicted apparent rumen digestion of starch and sugars (%).

Predicted apparent rumen digestion of starch and sugars tended to be lower than that observed (root MSPE of 2.7 % of observed mean) with an overall bias and deviation from the regression slope from unity contributing 30.2 % and 8.7 % to the MSPE. The overall mean was less well predicted than with for NDF and NAN and the simulation results show a small underprediction of the Sc degradation. This discrepancy is probably due to the higher range, between and among treatments, of observed values (87.4 to 94.9 %) when compared with the range of predicted values (88.8 to 90.5 %). According to Neal et al. (1992), differences between simulated and observed values should not be considered entirely due to inadequacy of the model, because inadequacies of input data describing the diets or errors in experimental measurements could also contribute to these differences.

The model presented a consistent overestimation of the rumen volume (V) of 25 and 10 % for low and high intake respectively. The equation used to predict V was developed by Chilibroste et al. (2001) using cows with average live weights of 574 kg and 618 kg. Filling constant observed values of V diminished the accuracy of the model because the rumen concentrations did not follow the intake variations. The underestimation is maybe due to the limited offer of food to 290 kg average LW animals. Diets with low intake (3.7 and 3.5 kg DM/d) presented the bigger differences in V when compared with high intake treatments (5.4 and 5.3 kg DM/d). The equation for V maybe needs to be adapted to simulate V of young cattle or limited feed diets.

Milk production

Assis et al. (1999) set up a feeding trial with dairy cows in order to validate the original model. Their data were used to test the behavior of the new version of the rumen model. The observed average milk yield was 11.2 l/day. They obtained accurate predictions with low lipid diets. However, with 3.2 kg

DM of whole soybean in the ration, the original model predicted less well. Therefore, Assis et al. (1999) decided to exclude the treatment with the high inclusion (3.2 kg) of whole soybean from the validation test and concluded that in diets with higher lipid levels, i.e. whole soybean, rice meal, cottonseeds, etc., the original model behavior was unsatisfactory.

In contrast to that previous validation test, a similar test with the new version of the rumen model used in the present study indicated good predictive behavior for all the four treatments. As shown in Figure 4, predictions of milk production (11.0 l/day) using energy, protein and glucose as predictors were quite close to real observations (11.2 l/day). Simulations presented a root MSPE of 3.4 l/d, i.e., 16.5 % of the observed mean and 76.5 % of MSPE attributed to the random disturbance proportion. The model has no consistent over- or underestimations with less than 1 % of MSPE attributed to overall bias deviation and 22.7 % to deviation of the regression slope from one. While the overall mean was predicted accurately, the observed variation in milk production caused by different supplements had some bias, possibly due to the small effect observed with different treatments.

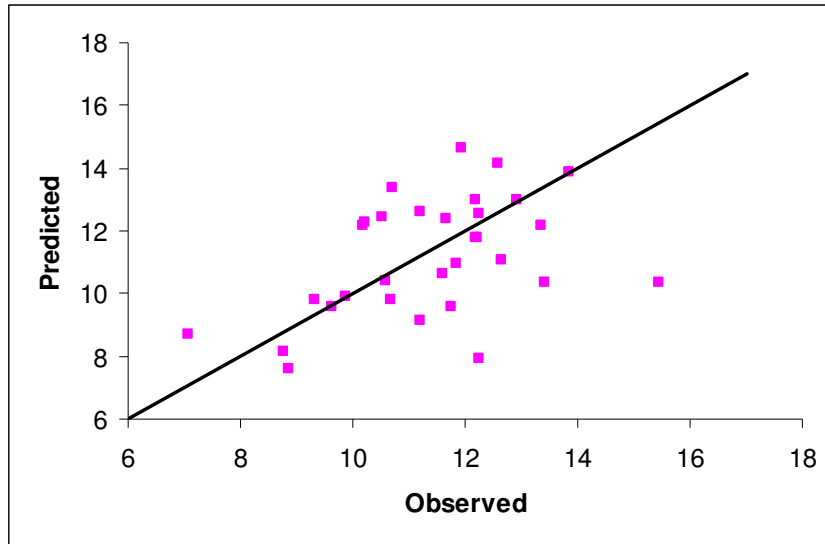

Figure 4. Comparison of observed and predicted values of daily milk production (l).

The simulated production is based on the most limiting nutrient. The previous simulations showed that protein requirements for milk production were not fulfilled by the offered rations in three (SM, 1.6 WS and 3.2WS) of the four treatments. Therefore, it would be necessary to include true protein sources in sugarcane based diets supplemented with whole soybeans and corn to adjust protein to the level of the other nutrients. Differently from the results of Assis et al. (1999) who found that protein limits milk production for all the four diets, the new version showed energy as the most limiting nutrient in the treatment with sugarcane supplemented with 1.6 kg DM of soybean meal. The same nutrients, protein for the treatments with whole soybeans and energy for the diet with soybean meal, restricted milk production in identical diet simulations performed with the CNCPS version 5.0 (Fox et al., 2003).

The results obtained in the present study seem more realistic because the protein fraction in soybeans as a supplement for cattle is highly degradable in the rumen which may result in low quantity of this protein fraction reaching the small intestine. Ganesh & Grieve (2002) reported that soybean meal has approximately 30% more nitrogen than raw soybeans in dry matter basis, 8.89% and 6.85% per kg DM respectively. The soluble fraction of nitrogen of soybean meal is less than 50% of that of raw soybeans (22.71 and 47.78 percent of total nitrogen respectively). NPN in soluble nitrogen is also higher in raw soybeans. Therefore, the addition of higher quantities of soluble nitrogen in diets supplemented with urea will not increase the amino acids in the intestine. Dawson et al., 1988 reported that supplementary protein feeds of inherently low rumen degradability like soybean meal have direct effects on the amount of undegraded dietary protein passing to the duodenum, but can also increase protein flow by stimulating carbohydrate digestion and microbial protein synthesis. In conclusion, the new model demonstrated good capability to predict milk production from cows fed sugarcane based diets supplemented with low or high lipid content.

4 CONCLUSIONS

The model presented reliable predictions under non steady-state conditions and seems to be useful to select strategies for supplementation of sugarcane based diets. Taking in account the limitation of the data sets available to test the model behavior, predicted outflow from the rumen generally corresponded with observed values. Although predicted and observed values of the apparent digestion of soluble sugars and starch were of the same magnitude, the observed variation could not be reproduced by the model. Possibly the equation that accounts for a rumen volume as a function of rumen DM content does not fit for low DM intakes. Therefore, new equations need to be derived before the model can be used to simulate growth or performance of other ruminant species. Further evaluation of the prediction accuracy of the model in non steady-state conditions requires observations from experiments in which the effects of ingestive behavior on rumen function are tested.

5 REFERENCES

- ALLEN, M. Effects of diet on short-term regulation of feed intake by lactating dairy cattle. **Journal of Dairy Science**, Savoy, v. 83, n. 7, p. 1598-1624, July 2000.
- ALLEN, M. S.; MERTENS, D. R. Evaluating constraints on fiber digestion by rumen microbes. **Journal of Nutrition**, Bethesda, v. 118, n. 2, p. 261-270, Feb. 1988.
- ASSIS, A. G.; LOPES, F. C. F.; DURÃES, M. C.; SIMÕES, J. B.; ANDRADE, R. S.; VERARDO JUNIOR, A. E. Validação de um modelo de simulação da cinética de nutrientes em vacas leiteiras. In: REUNIÃO ANUAL DA SOCIEDADE BRASILEIRA DE ZOOTECNIA, 36., 1999, Porto Alegre. **Anais....** São Paulo: Gnosis, 1999. CD-ROM. Nutrição de ruminantes. Bezerros e gado leiteiro. NUR-008.
- BALDWIN, R. L. **Modeling ruminant digestion and metabolism**. London: Chapman & Hall, 1995. 592 p.
- BALDWIN, R. L.; THORNLEY, J. H. M.; BEEVER, D. E. Metabolism of the lactating cow. II. Digestive elements of a mechanistic model. **Journal of Dairy Research**, Cambridge, v. 54, n. 1, p. 107-131, Feb. 1987.
- BANNINK, A.; DE VISSER, H. Comparison of mechanistic rumen models on mathematical formulation of extramicrobial and microbial processes. **Journal of Dairy Science**, Savoy, v. 80, n. 7, p. 1296-1314, July 1997.
- BIBBY, J.; TOUTENBURG, H. **Prediction and improved estimation in linear models**. Cichester, UK: John Wiley & Sons, 1977. 188 p.
- BOUDON, A.; PEYRAUD, J. L. The release of intracellular constituents from fresh ryegrass (*Lolium perenne* L.) during ingestive mastication in dairy cows: effect of intracellular constituent, season and stage of maturity. **Animal Feed Science and Technology**, Amsterdam, v. 93, n. 3/4, p. 229-245, Oct. 2001.
- BOUDON, A.; PEYRAUD, J. L.; FAVERDIN, P. The release of intracellular constituents from fresh ryegrass (*Lolium perenne* L.) during digestion in dairy cows: effect of intracellular constituent, season and stage of maturity. **Animal Feed Science and Technology**, Amsterdam, v. 97, n. 1/2, p. 83-102, May 2002.
- CHILIBROSTE, P.; DIJKSTRA, J.; TAMMINGA, S. Design and evaluation of a non-steady state rumen model. **Netherlands Journal of Agricultural Science**, Wageningen, v. 49, n. 4, p. 297-312, Dec. 2001.

- CORREA, C. E. S.; PEREIRA, M. N.; OLIVEIRA, S. G. de; RAMOS, M. H. Performance of Holstein cows fed sugarcane or corn silages of different grain textures. **Scientia agricola**, Piracicaba, v. 60, n. 4, p. 621-629, Oct./Dec. 2003.
- DAWSON, J. M.; BRUCE, C. I.; BUTTERY, P. J.; GILL, M.; BEEVER, D. E. Protein metabolism in the rumen of silage-fed steers: effect of fishmeal supplementation. **British Journal of Nutrition**, Cambridge, v. 60, n. 2 p. 339-353, Sept. 1988
- DHIMAN, T. R.; KOREVAAR, A. C.; SATTER, L. D. Particle size of roasted soybeans and the effect on milk production of dairy cows. **Journal of Dairy Science**, Savoy, v. 80, n. 8, p. 1722-1727, Aug. 1997.
- DIJKSTRA, J.; FRANCE, J. Modelling interactions among microorganisms in the reticulo-rumen In: INTERNATIONAL SYMPOSIUM ON MICROBIAL ECOLOGY, 7., 1995, São Paulo. **Proceedings**. . . São Paulo, 1995. p. 297-309.
- DIJKSTRA, J.; FRANCE, J.; ASSIS, A. G.; NEAL, H. D. ST. C.; CAMPOS, O. F.; AROEIRA, L. J. M. Simulation of digestion in cattle fed sugar cane: prediction of nutrient supply for milk production with locally available supplements. **Journal of Agricultural Science**, Cambridge, UK, v. 127, n. 2, p. 247-260, Sept. 1996a.
- DIJKSTRA, J.; FRANCE, J.; NEAL, H. D. ST. C.; ASSIS, A. G.; AROEIRA, L. J. M.; CAMPOS, O. F. Simulation of digestion in cattle fed sugar cane: model development. **Journal of Agricultural Science**, Cambridge, UK, v. 127, n. 2, p. 231-246, Sept. 1996b.
- FIGUEIRA, D. G. **Efeito do nível de uréia sobre as digestibilidades aparente e *In situ*, e a dinâmica da fase sólida em bovinos alimentados com cana-de-açúcar e farelo de algodão**. 1991. 132 p. Dissertação (Mestrado em Zootecnia) - Universidade Federal de Minas Gerais, Belo Horizonte.
- FOX, D. G.; TYLUTKI, T. P.; TEDESCHI, M. E.; VAN AMBURGH, M. E.; CHASE, L. E.; PELL, A. N.; OVERTON, T. R.; RUSSELL, J. B. **The net carbohydrate and protein system for evaluating herd nutrition and nutrient excretion (CNCPS version 5.0)**. Ithaca: Cornell University, 2003. 237 p. (Extension Bulletin, n. 213). .
- GANESH, D.; GRIEVE, D. G. Effect of roasting raw soybeans at three temperatures on in situ dry matter and nitrogen disappearance in dairy cows. **Journal of Dairy Science**, Champaign, v. 73, n. 11, p. 3222-3230, Nov. 2002.
- GERRITS, W. J. J. **Modelling the growth of preruminant calves**. 1996. 195 p. Thesis (Ph. D. in Animal Nutrition) - Wageningen Agricultural University, Wageningen, The Netherlands.

KUSMARTONO, A.; SHIMADA, A.; STAFFORD, K. J. Intra-ruminal particle size reduction in deer fed fresh perennial ryegrass (*Lolium perenne*) or chicory (*Cichorium intybus*). **Journal of Agricultural Science**, Cambridge, v. 127, n. 4, p. 525-531, Dec. 1996.

LAREDO, M. A.; MINSON, D. J. The voluntary intake, digestibility, and retention time by sheep of leaf and stem fractions of five grasses. **Australian Journal of Agricultural Research**, Melbourne, v. 24, n. 4, p. 875-888, Nov. 1973.

LENG, R. A.; PRESTON, T. R. Sugarcane for cattle production: Present constraints, perspectives and research priorities. **Tropical Animal Production**, Santo Domingo, v. 1, n. 1, p. 1-22, 1976.

MATOS, J. M. N. **Níveis de ingestão de alimentos e de uréia sobre alguns parâmetros ruminais e digestão total e parcial em bovinos, alimentados com dieta à base de cana-de-açúcar e uréia suplementada com farelo de arroz.** 1991. 119 p. Tese (Doutorado em Zootecnia) – Universidade Federal de Viçosa, Viçosa, MG.

MENDONÇA, S. S.; CAMPOS, J. M. S.; VALADARES FILHO, S. C.; VALADARES, R. F. D.; LANA, R. de P.; SOARES, C. A.; PINA D. dos S.; MACHADO, J. C. Cana-de-açúcar como volumoso único para vacas de leite. 3. Consumo e digestibilidade aparente dos nutrientes In: REUNIÃO ANUAL DA SOCIEDADE BRASILEIRA DE ZOOTECNIA, 39., 2002, Recife, PE. **Anais...** Recife : SBZ, 2002. 1 CD ROM.

MERTENS, D. R. Nonstructural and structural carbohydrates. In: HORN, H. H. van; WILCOX, C. J. **Large dairy herd management**. Savoy: ADSA Savoy, 1999. p. 219-235.

MIRANDA, L. F.; QUEIROZ, A. C. de; VALADARES FILHO, S. C.; CECON, P. R.; PEREIRA, E. S.; SOUZA, J. M. C. de; LANNA, R. P.; MIRANDA, J. F. Comportamento ingestivo de novilhas leiteiras alimentadas com dietas à base de cana-de-açúcar. **Revista Brasileira de Zootecnia**, Viçosa, MG, v. 28, n. 3, p. 614-620, maio/jun. 1999.

MURPHY, M. R.; BALDWIN, R. L.; ULYATT, M. J. An update of a dynamic model of ruminant digestion. **Journal of Animal Science**, Champaign. v. 62, n. 5, p. 1412-1422, May 1986.

NEAL, H. D. ST. C.; DIJKSTRA, J.; GILL, M. Simulation of nutrient digestion, absorption and outflow in the rumen: model evaluation. **Journal of Nutrition**, Bethesda, v. 122, n. 11, p. 2257-2272, Nov. 1992.

NOCEK, J. E.; TAMMINGA, S. Site of digestion of starch in the gastrointestinal tract of dairy cows and its effect on milk yield and composition. **Journal of Dairy Science**, Champaign, v. 74, n. 10, p. 3598-3629, Oct. 1991.

PATE, F. M.; FAIR HURST, P. M.; MUNTHALI, J. T. K. Urea level and supplemental energy sources in sugarcane diets. **Journal of Animal Science**, Champaign. v. 61, n. 1, p. 252-259, Jan. 1985.

RIBEIRO, E. G.; ESTRADA, L. H. C.; FONTES, C. A. A.; AGUIAR, R. S.; ROCHA, L. V. Níveis de substituição da silagem de milho pela cana-de-açúcar na alimentação de vacas de leite (consumo alimentar). In: REUNIÃO ANUAL DA SOCIEDADE BRASILEIRA DE ZOOTECNIA, 37., 2000, Viçosa. **Anais...** Viçosa: SBZ, 2000. 1 CD-ROM.

RUSSELL, J. B.; BALDWIN, R. L. Comparison of maintenance energy expenditures and growth yields among several rumen bacteria grown on continuous culture. **Applied and Environmental Microbiology**, Washington, v. 37, n. 3, p. 537-543. Mar. 1979.

RUSSELL, J. B.; BALDWIN, R. L. Substrate preferences in rumen bacteria: evidence of catabolite regulatory mechanisms. **Applied and Environmental Microbiology**, Washington, v. 36, n. 2, p. 319-329. Aug. 1978.

APPENDIX

	Page
TABLE 1	
Predicted and observed (Matos, 1991) values of NDF and NAN rumen outflow and apparent rumen degradation of starch and sugars.	71
TABLE 2	
General notation used in the model	72
Mathematical statement of original model (Dijkstra et al. 1996a)	73

Table 1. Predicted and observed (Matos, 1991) values of NDF and NAN rumen outflow and apparent rumen degradation of starch and sugars

Animal	Treatment	NDF Flow		NAN Flow		Apparent degradation	
		Observed	Predicted	Observed	Predicted	Observed	Predicted
1	LILU	1095.0	1278.3	44.48	44.81	93.88	88.93
2	LILU	1156.0	1278.3	45.76	44.81	93.12	88.93
3	LILU	1295.0	1211.4	53.92	42.13	89.60	88.76
4	LILU	1264.0	1313.7	43.20	46.24	88.77	89.00
5	LILU	1227.0	1272.3	45.44	44.57	90.55	88.90
6	LILU	1416.0	1233.7	44.96	43.03	88.73	88.82
7	HILU	1462.0	1744.4	56.48	64.89	91.30	89.90
8	HILU	2020.0	1897.6	70.72	70.75	89.52	90.03
9	HILU	1248.0	1693.3	50.72	62.27	92.43	88.83
10	HILU	1864.0	1931.9	88.96	72.17	88.63	90.06
11	HILU	1534.0	1771.8	65.12	65.52	90.72	89.90
12	HILU	1710.0	1693.3	60.00	62.27	88.77	88.83
13	LIHU	945.0	1293.9	45.12	45.35	94.93	89.40
14	LIHU	1056.0	1190.9	38.24	41.24	90.76	89.20
15	LIHU	1195.0	1174.6	45.28	40.60	90.63	89.13
16	LIHU	867.0	1091.6	57.12	37.31	89.35	88.89
17	LIHU	1475.0	1322.2	60.48	46.48	90.78	89.50
18	LIHU	969.0	1217.2	45.92	42.29	91.82	89.24
19	HIHU	1559.0	1370.4	37.76	48.76	93.78	89.70
20	HIHU	1622.0	1616.7	75.52	58.83	87.38	90.10
21	HIHU	1268.0	1387.7	47.52	49.46	93.74	89.80
22	HIHU	1579.0	1873.3	64.32	69.39	91.94	90.40
23	HIHU	2314.0	1988.0	72.48	74.12	89.46	90.50
24	HIHU	2021.0	1746.9	67.20	64.19	88.91	90.30
25	HIHU	1764.0	1725.5	54.72	63.31	92.02	90.20

¹ LILU, low intake and 10g of urea/kg fresh sugarcane; HILU, high intake and 10g of urea /kg fresh sugarcane; LIHU, low intake and 15g of urea /kg fresh sugarcane; HIHU, high intake and 15g of urea /kg fresh sugarcane.

Table 2. General notation used in the model

Notation	Translation	Units
A_i	Absorption rate of i.....	(g or mmol i) /h
C_i	Concentration of i.....	(g or mmol i) /l
D_i	Dietary input of i.....	(g or mmol i) /h
k_{ij}	Fractional rate constant for i-j transaction...	/h
$J_{i,jk}$	Inhibition constant for j-k transaction with respect to i.....	g i/l
$M_{i,jk}$	Affinity constant for j-k transaction with respect to i	g i/l
$P_{i,jk}$	Rate of production of i in j-k transaction...	(g or mmol i) /h
Q_i	Quantity of i.....	g or mmol i
$R_{i,jk}$	Requirement for i in j-k transaction	g i/gj
t	Time	h
$U_{i,jk}$	Rate of utilization of i by j-k transaction...	g i/h
V_{ij}	Velocity for i-j transaction.....	g i/g Mi/h
$Y_{i,jk}$	Yield of i for j-k transaction.....	(g or mmol i) /(g j)

Mathematical statement of original model (Dijkstra et al., 1996a)

Undegradable protein pool, QPu (g)

Concentration: $CPu = QPu/V$ (1.1)

Input: $PPu, InPu = DPu$ (1.2)

Output: $UPu, Puex = KSoExQPu$ (1.3)

Differential equation: $dQPu/dt = PPu, InPu - UPu, PuEx$ (1.4)

Insoluble, degradable protein pool, QPd(g)

Concentration: $CPd = QPd/V$ (2.1)

Input: $PPd, InPd = DPd$ (2.2)

Outputs: $UPd, PdPs = kPdPsCmi/C^* MiQPd$ (2.3)

$UPd, PdEx = kSoExQPd$ (2.4)

Differential equation: $dQPd/dt = PPd, InPd - UPd, PdPs - UPd, PdEx$ (2.5)

Soluble protein pool, QPs(g)

Concentration: $CPs = QPs/V$ (3.1)

Inputs: $PPs, InPs = Dps$ (3.2)

$PPs, PdPs = YPs, PdPsUPd, PdPs$ (3.3)

Outputs:

$UPs, PsMi = PsMiQMi / (1 + MPs, PsMi/CPs + MSc, PsMi/CSc + MLd, PsMi/CLd)$ (3.4)

$UPs, PsAm = VPsAmQMi / (1 + MPs, PsAm/CPs + CSc/JSc, PsAm)$ (3.5)

$UPs, PsEx = kFlExQPs$ (3.6)

Differential equation: $dQps/dt = PPs, InPs + PPs, PdPs - UPs, PsMi - UPs, PsAm - UPs, PsEx$ (3.7)

Ammonia pool, QAm(g)

Concentration: $C_{Am} = Q_{Am}V$ (4.1)

Inputs: $P_{Am,InAm} = D_{Am}$ (4.2)

$$P_{Am,UrAm} = \frac{Y_{Am,UrAm}D_{Ni}}{(1 + C_{Am}/J_{Am,UrAm})}$$
 (4.3)

$$P_{Am,PsAm} = Y_{Am,PsAm} U_{Ps,PsAm}$$
 (4.4)

Outputs: $U_{Am,PsMi} = R_{Am,PsMi} U_{Ps,PsMi}$ (4.5)

$$U_{Am,AmMi} = \frac{V_{AmMi}Q_{Mi}}{(1 + M_{Am,AmMi}/C_{Am} + C_{Ps}/J_{Ps,AmMi} + M_{Sc,AmMi}/C_{Sc} + M_{Ld,AmMi}/C_{Ld})}$$
 (4.6)

$$U_{Am,AmAb} = k_{AmAb}Q_{Am} = A_{Am}$$
 (4.7)

$$U_{Am,AmEx} = k_{F_{Ex}}Q_{Am}$$
 (4.8)

Differential equation: $dQ_{Am}/dt = P_{Am,InAm} + P_{Am,UrAm} + P_{Am,PsAm} - U_{Am,PsMi} - U_{Am,AmMi} - U_{Am,AmAb} - U_{Am,AmEx}$ (4.9)

Long chain fatty acid pool, QLd (g)

Concentration: $C_{Ld} = Q_{Ld}/V$ (5.1)

Input: $P_{Ld,InLd} = D_{Ld}$ (5.2)

Outputs: $U_{Ld,AmMi} = R_{Ld,AmMi} U_{Am,AmMi}$ (5.3)

$$U_{Ld,PsMi} = R_{Ld,PsMi} U_{Ps,PsMi}$$
 (5.4)

$$U_{Ld,LdEx} = k_{SoEx}Q_{Ld}$$
 (5.5)

Differential equation: $dQ_{Ld}/dt = P_{Ld,InLd} - U_{Ld,AmMi} - U_{Ld,PsMi} - U_{Ld,LdEx}$ (5.6)

Undegradable fibre pool, QFu(g)

Concentration: $C_{Fu} = Q_{Fu}/V$ (6.1)

Input: $P_{Fu,InFd} = D_{Fd}$ (6.2)

$$\text{Output: } U_{Fu}, F_{uEx} = k_{SoEx} Q_{Fu} \quad (6.3)$$

$$\text{Differential equation: } dQ_{Fu}/dt = P_{Fu}, In_{Fu} - U_{Fu}, F_{uEx} \quad (6.4)$$

Degradable fibre pool, Q_{Fd} (g)

$$\text{Concentration: } C_{Fd} = Q_{Fd}/V \quad (7.1)$$

$$\text{Input: } P_{Fd}, In_{Fd} = D_{Fd} \quad (7.2)$$

$$\text{Outputs: } U_{Fd}, F_{dSc} = k_{FdSc} C_{Mi}/C^* Mi Q_{Fd} \quad (7.3)$$

$$U_{Fd}, F_{dEx} = k_{SoEx} Q_{Fd} \quad (7.4)$$

$$\text{Differential equation: } dQ_{Fd}/dt = P_{Fd}, In_{Fd} - U_{Fd}, F_{dSc} - U_{Fd}, F_{dEx} \quad (7.5)$$

Insoluble starch pool, Q_{Si} (g)

$$\text{Concentration: } C_{Si} = Q_{Si}/V \quad (8.1)$$

$$\text{Input: } P_{Si}, In_{Si} = D_{Si} \quad (8.2)$$

$$\text{Outputs: } U_{Si}, Si_{Sc} = k_{SiSc} C_{Mi}/C^* Mi Q_{Si} \quad (8.3)$$

$$U_{Si}, Si_{Ex} = k_{SoEx} Q_{Si} \quad (8.4)$$

$$\text{Differential equation: } dQ_{Si}/dt = P_{Si}, In_{Si} - U_{Si}, Si_{Sc} - U_{Si}, Si_{Ex} \quad (8.5)$$

Soluble starch and sugars pool, Q_{Sc} (g)

$$\text{Concentration: } C_{Sc} = Q_{Sc}/V \quad (9.1)$$

$$\text{Inputs: } P_{Sc}, In_{Sc} = D_{Sc} \quad (9.2)$$

$$P_{Sc}, In_{Ld} = Y_{Sc}, In_{Ld} D_{ld} \quad (9.3)$$

$$P_{Sc}, F_{dSc} = Y_{Sc}, F_{dSc} U_{Fd}, F_{dSc} \quad (9.4)$$

$$P_{Sc}, Si_{Sc} = Y_{Sc}, Si_{Sc} U_{Si}, Si_{Sc} \quad (9.5)$$

$$\text{Outputs: } U_{Sc}, Am_{Mi} = R_{Sc}, Am_{Mi} U_{Am}, Am_{Mi} \quad (9.6)$$

$$U_{Sc}, Ps_{Mi} = R_{Sc}, Ps_{Mi} U_{Ps}, Ps_{Mi} \quad (9.7)$$

$$U_{Sc}, Sc_{Va} = V^{(1)} Sc_{Va} Q_{mi} + V^{(2)} Sc_{Va} Q_{Mi} / (1 + M_{Sc}, Sc_{Va} / C_{Sc} + C_{Ps} / J_{Ps}, Sc_{Va}) \quad (9.8)$$

$$U_{Sc}, Sc_{Ex} = k_{F_{lEx}} Q_{Sc} \quad (9.9)$$

Differential equation: $dQ_{Sc}/dt = P_{Sc,InSc} + P_{Sc,InLd} + P_{Sc,FdSc} + P_{Sc,SiSc} - U_{Sc,AmMi} - U_{Sc,PsMi} - U_{Sc,ScVa} - U_{Sc,ScEx}$ (9.10)

Microbial pool, Q_{Mi} (g)

Concentration: $C_{Mi} = Q_{Mi}/V$ (10.1)

Inputs: $P_{Mi,AmMi} = Y_{Mi,AmMi} U_{Am,AmMi}$ (10.2)

$P_{Mi,PsMi} = Y_{Mi,PsMi} U_{Ps,PsMi}$ (10.3)

Outputs : $U_{Mi,MiEx} = (0.2k_{SoEx} + 0.45k_{ScEx} + 0.15k_{FIEx}) Q_{Mi}$ (10.4)

Differential equation: $dQ_{Mi}/dt = P_{Mi,AmMi} + P_{Mi,PsMi} - U_{Mi,MiEx}$ (10.5)

Rumen volatile fatty acid pool, Q_{Va} (mol)

Concentration : $C_{Va} = Q_{Va} / V$ (11.1)

Inputs: $P_{Va,InVa} = D_{Va}$ (11.2)

$P_{Va,AmMi} = Y_{Va,AmMi} U_{Sc,AmMi}$ (11.3)

$P_{Va,PsMi} = Y_{Va,PsMi} U_{Sc,PsMi}$ (11.4)

$P_{Va,ScVa} = Y_{Va,ScVa} U_{Sc,ScVa}$ (11.5)

$P_{Va,PsAm} = Y_{Va,PsAm} U_{Ps,PsAm}$ (11.6)

Outputs : $U_{Va,VaAb} = k_{VaAb} Q_{Va}$ (11.7)

$U_{Va,VaEx} = k_{FIEx} Q_{Va}$ (11.8)

Differential equation: $dQ_{Va}/dt = P_{Va,InVa} + P_{Va,AmMi} + P_{Va,PsMi} + P_{Va,ScVa} + P_{Va,PsAm} - U_{Va,VaAb} - U_{Va,VaEx}$ (11.9)

Amino acid zero pool, $Aa(g)$

Balance equation: $A_{aa} = U_{Pd,PdEx} + U_{Ps,PsEx} + 0.463 U_{Mi,MiEx}$ (12.1)

Glucose zero pool, Gl(g)

Balance equation:

$$AGI = U_{Sc, ScEx} + 0.202U_{Mi, MiEx} + 0.75(U_{Si, SiSc/DSi})U_{Si, SiEx} \quad (13.1)$$

Long Chain fatty acids zero pool, Li(g)

$$\text{Balance equation: } ALi = 0.9(U_{Ld, LdEx} + 0.0805U_{Mi, MiEx}) \quad (14.1)$$

Volatile fatty acids zero pool, Vf(mol)

$$\begin{aligned} \text{Balance equation: } AVf = U_{Va, VaEx} + 10.64\{0.25(U_{Si, SiSc/DSi})U_{Si, SiEx} \\ + 0.11U_{Fd, FdSc}\} \quad (15.1) \end{aligned}$$