

Maps of deformations in a cantilever beam using particle image velocimetry (PIV) and speckle patterns

<http://dx.doi.org/10.1590/0370-44672013680016>

Roberto Alves Braga Jr.

Professor Associado
University of Lavras,
Engineering department
Lavras – Minas Gerais – Brasil
robbraga@deg.ufla.br

Ricardo Rodrigues Magalhaes

Professor Adjunto
University of Lavras,
Engineering department
Lavras – Minas Gerais – Brasil
ricardorm@deg.ufla.br

Rafael Pego Melo

Bolsista de Iniciação Científica
University of Lavras,
Engineering department
Lavras – Minas Gerais – Brasil
rafamelo@engautomacao.ufla.br

Joao Vitor Gomes

Bolsista de Iniciação Científica
University of Lavras,
Engineering department
Lavras – Minas Gerais – Brasil
jv_aut@hotmail.com

1. Introduction

Deformations that occurred in industrial parts caused by external loads (fatigue) or manufacturing processes (residual stresses) affect resistance and generally compromise the product's life. Measurement of these deformations in terms of displacements with no product damages has significant importance in industries and also in researching.

Methods for measuring deformations to detect failures in components can be used in industry as a way of destructive techniques, such as torsion tests (Barcelos, 2013) or semi-destructive, such as the hole drilling method (Diaz *et al.*, 2000). Non-destructive tests (e.g. x-ray, ultrasound, shearography and holography) can be useful when one does not want to destroy or even stay in contact with the material under analysis. These optical methods can

Abstract

PIV (particle image velocimetry) has been spreading in studies that use the movement of particles to monitor the displacement of an object or the flow of a fluid by means of velocity vectors using optical techniques and second order statistics. PIV is also known as laser speckle velocimetry when associated with speckle patterns. This technique has been used in works involving fluids, in general, building a map of velocity vectors representing the flow under analysis. This paper presents an approach by using PIV associated to speckle patterns for deformation measurements in a cantilever beam (ASTM A36 steel), one of the most common examples used in civil engineering, without the introduction of external particles. Results showed that the difference between PIV associated to speckle patterns and the analytic displacement values is increased along the beam length for a load of 1.96 N as an evidence of sensitivity of the proposed measurement method. This indicates that PIV is also capable for detecting displacement fields associated with laser speckle patterns in solid mechanics generating a map of deformation as an additional option for non-destructive tests.

Keywords: Particle image velocimetry, displacement vectors, solid mechanics, measurement techniques.

be classified as in-plane and out-of-plane techniques. One feasible technique to measure displacements is particle image velocimetry (PIV), which had its origin in the researches of solid mechanics displacements and is commonly linked to laser speckle velocimetry (LSV) (Adrian, 2005). Therefore, PIV and LSV can only be distinguished by the so called source density, which means the amount of particles in the same place. In a speckle pattern, one has a high density of particles, characterizing the LSV approach, while the low density of particles are commonly linked to the PIV applications in fluids measurements (Adrian, 1991; Volker *et alli*, 2011; Ertürk *et alli*, 2013; Xu and Chen, 2013).

Otherwise, PIV has been used in solid mechanics measuring, for instance, the movement of soil which has a white powder

scattered over the surface to act as particles (Baba and Peth, 2012) or to monitor the growth of a root (Hamza *et al.* 2006).

In order to avoid the introduction of external particles, Soares *et al.* (2013) suggested the association of PIV with speckle patterns in order to provide micro-fluid measurements, and therefore, the main hypothesis of this work was to prove the feasibility of the association of the PIV technique to speckle laser patterns, also known as the LSV technique, to measure deformations and create maps of vectors in a steel beam.

An ASTM A36 steel (ASTM, 2012) beam with rectangular cross section, commonly used in civil engineering applications, has been used in the experiments. In terms of metallurgy, this kind of steel is one of the most used materials in welded joints

because it does not need special heat treatments (Magalhaes *et al.*, 2014). Also ASTM A36 has a large number of applications in structural assemblies as a result of its per-

2. Material and methods

In the experiments, used was an ASTM A36 steel cantilever beam with a

Carbon (max, %)	Manganese (%)	Phosphorus (max, %)	Sulfur (max, %)	Silicon (max, %)	Copper (N/m ²)
0.26	---	0.04	0.05	0.40	0.20

Density (kg/m ³)	Poisson's ratio	Yield strength (N/m ²)	Tensile strength (N/m ²)	Young's modulus (N/m ²)	Shear modulus (N/m ²)
7850	0.26	2.5x10 ⁸	4.0x10 ⁸	2.0x10 ¹¹	7.9x10 ¹⁰

In the experiments, the laser beam illuminated the sample in a specific region and the scattered light was captured by a CCD camera for the first image without any deformation of the steel. The second

formance in terms of mechanical resistance.

This work was focused on applying PIV as an optical technique related to in-plane deformations in solids me-

rectangular cross section (28 x 3.175 mm) and length of 130 mm. Table 1 and Table

image was similar to the first one, but with the displacement of the particles introduced after the load application and the deformation of the beam. The difference between the two speckle images (before and after

chanics, where the speckle patterns were taken before and after application of loads on a steel cantilever beam with a rectangular cross section.

2 show the chemical and mechanical properties, respectively, for this kind of steel.

Table 1
ASTM A36 steel chemical properties (ASTM, 2012)

Table 2
ASTM A36 steel mechanical properties.

load application of the load) was the inputs from PIV which generated the map of velocity vectors. A specific device setup was built in order to proceed with the experiments, schematically showed in Figure 1.

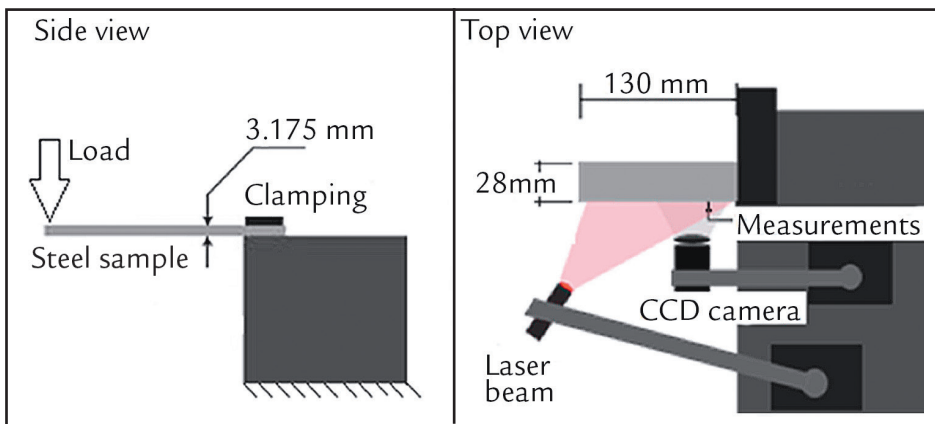

Figure 1
Experimental setup scheme.

Results were compared to analytic displacements which are represented by

Equation 1. The vertical displacement at the beam centerline is represented as:

$$v = \frac{P}{2EI} \left(Lx^2 - \frac{x^3}{3} \right) \quad (1)$$

where v is the vertical displacement (mm), P is the load (N), E is the material Young's modulus (MPa), I is

the moment of inertia (mm⁴), L is the length of the beam (mm) and x is the distance between the displacement

measurement point and clamping position (mm) (Dym and Shames, 2013).

3. Results

The speckle pattern was obtained from the illuminated sample by a solid state laser of 632 nm with 3mW and the images were captured by a CCD camera before and after the application of the loads. Standard loads were applied with a range of 0.01 to 5.0 kg in order to evaluate the sensitivity level of the technique. In

order to generate displacements vectors, the commercial software (MATLAB® version 7.8.0.347 R2009A) was used, which performed image analyses from the code MPIV (version 0.97) by using the parameters [xi, yi, iu, iv] = mpiv (im1, im2, 128, 128, 0.5, 0.5, 20, 20, 1, 'color', 2, 1).

The PIV outcomes were used to visu-

ally evaluate the map of displacements by arrows which represented the magnitude and direction of the movements. The arrows are the representation of a cross-correlation between each window of the image with their expression in another moment. The plotted arrow regarding the cross-correlation of the all particles within

each window is therefore a summary as a mean value of length and direction (Adrian, 1991). In Fig. 2c each arrow represents the summary of the displacement of all particles with in each area of the image, where the particles before and

after the displacement are represented by the speckle grains showed in Fig. 2a and Fig. 2b, respectively.

Some Finite Element Method (FEM) commercial software can also represent displacements vectors. Figure 2d shows

the representation of FEM displacements vectors caused by a simulated load of 1.96 N. Recent works showed good agreement between PIV and FEM in terms of displacements as presented by Magalhaes *et al.* (2015).

Figure 2
a) Picture before the load application;
b) Picture after the load application;
c) PIV results;
d) FEM results.

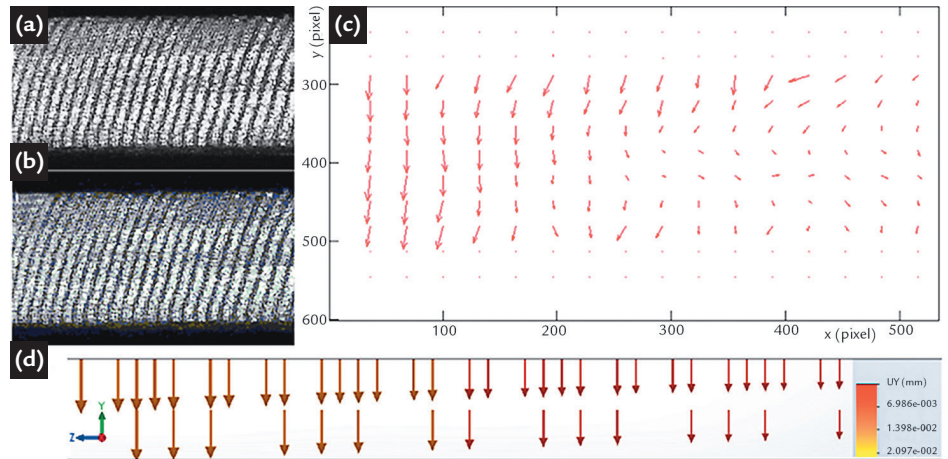

By applying Equation 1, the analytic displacements were obtained at the same points of the PIV results in order to com-

pare them. Figure 3 shows the results from loads of 0.98 N (Fig 3a), 1.96 N (Fig 3b) and 4.9 N (Fig 3c) which presented no loss

of correlation during image processing in a range from 19.54 mm to 33.41 mm from the clamping position (zero x coordinate).

Figure 3.a
Analytic and PIV
displacements for load of 0.98 N.

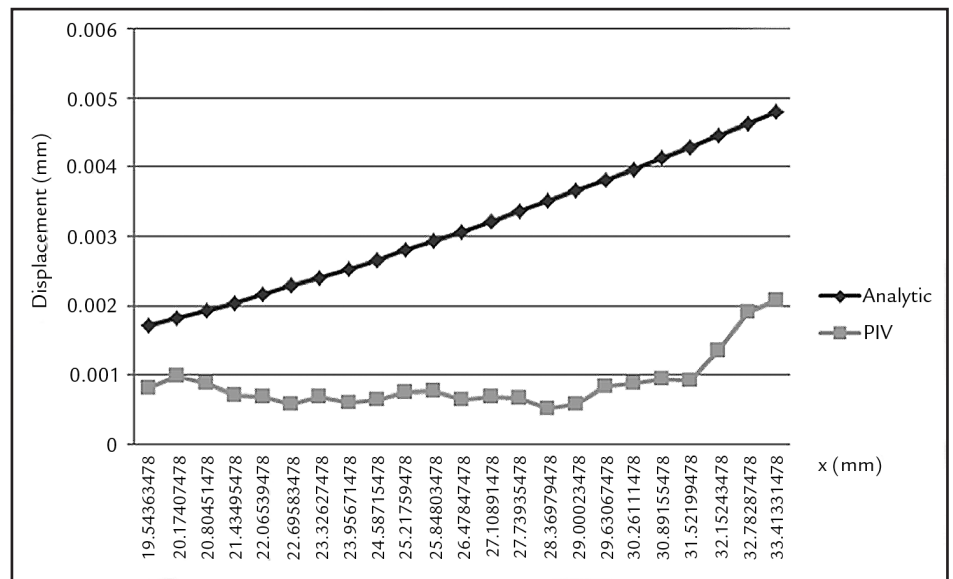
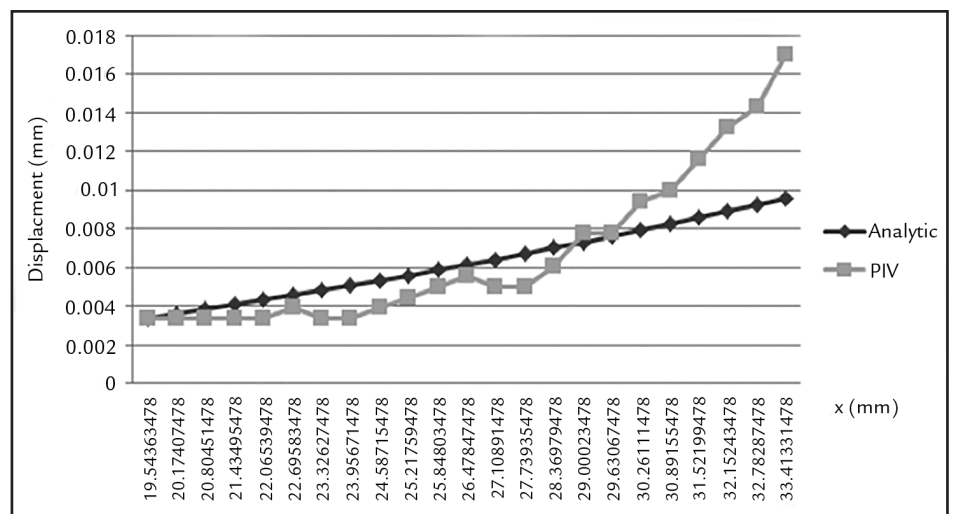

Figure 3.b
Analytic and PIV
displacements for load of 1.96 N.



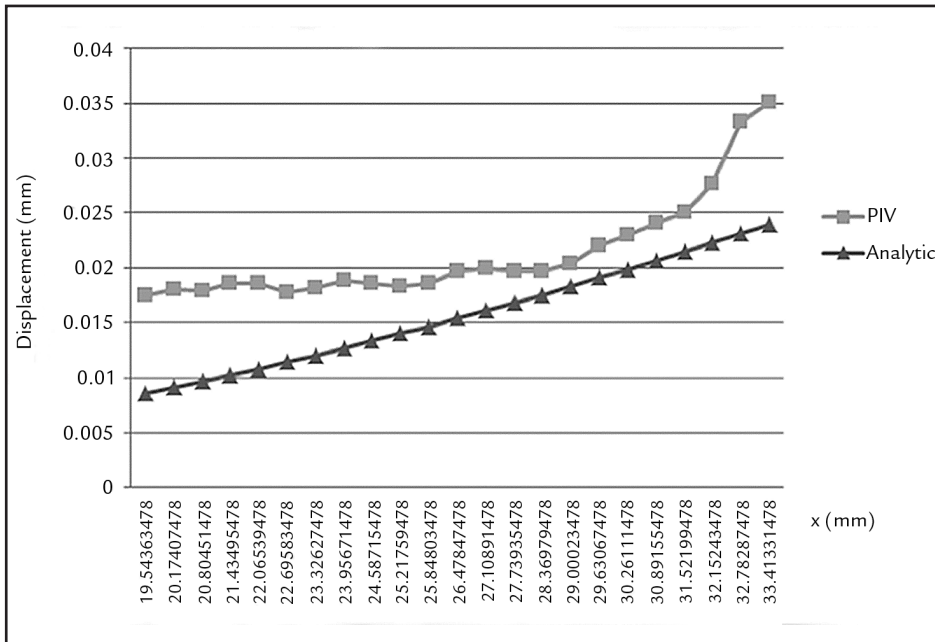

Figure 3.c
Analytic and PIV
displacements for load of 4.9 N.

Figure 4 shows the correlation between PIV and analytic data related to the results obtained from the load of 1.96

N, in the same portion of the beam which presented best displacements fitness. Also displayed is a 3rd order polynomial equation and its respective R-squared value on chart.

tion and its respective R-squared value on chart.

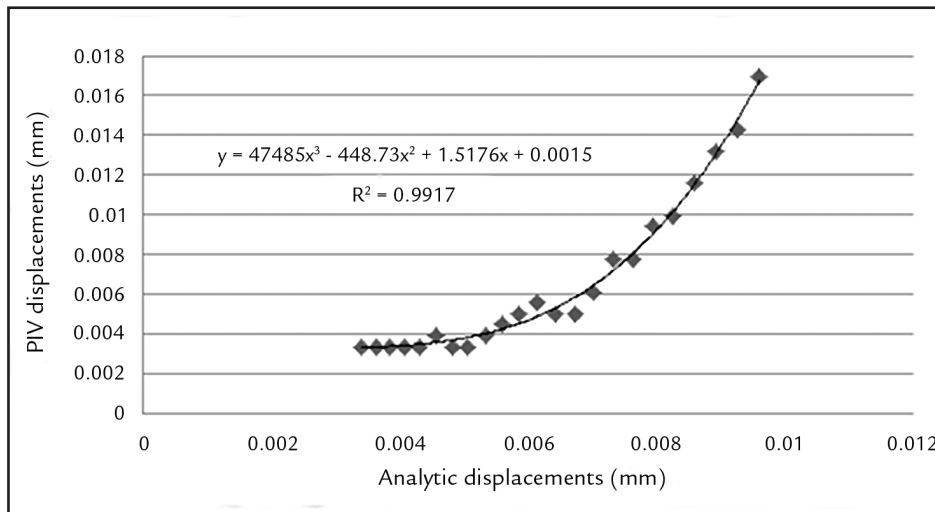

Figure 4
Analytic and PIV correlation data.

Other laser positions were considered for covering a larger range of points in the cantilever beam, and new

values were obtained from windows of 41.8 mm to 54.7 mm, 63.8 mm to 78 mm and 86.4 mm to 100.86 mm as

regards to the clamping position (zero x coordinate) as shown in the Figure 5.

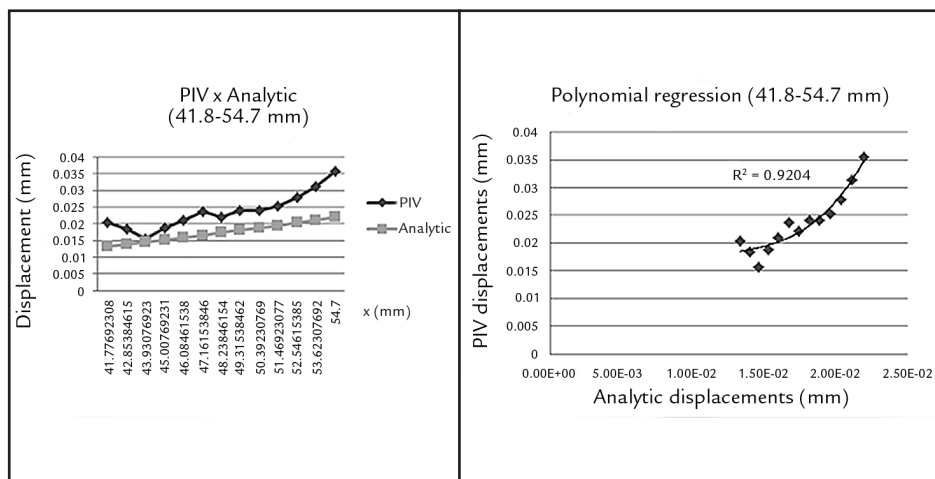

Figure 5.a
PIV vs. Analytic for 41.8-54.7 mm
and its respective R-squared correlation.

Figure 5.b
PIV vs. Analytic for 63.8-78 mm
and its respective R-squared correlation.

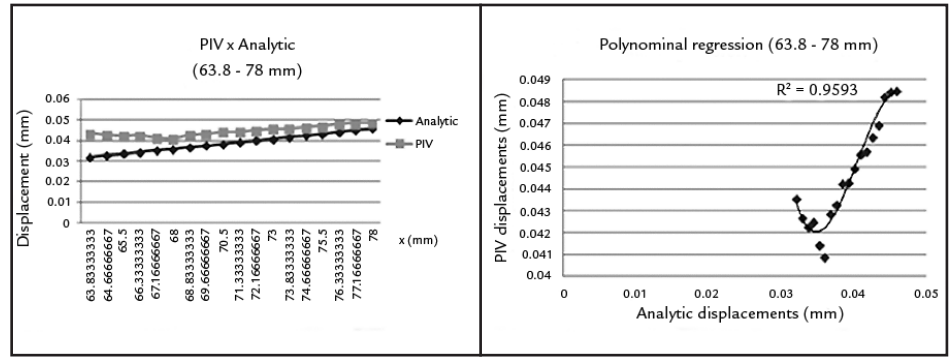

Figure 5.c
PIV vs. results for 86.4-100.6 mm
and its respective R-squared correlation.

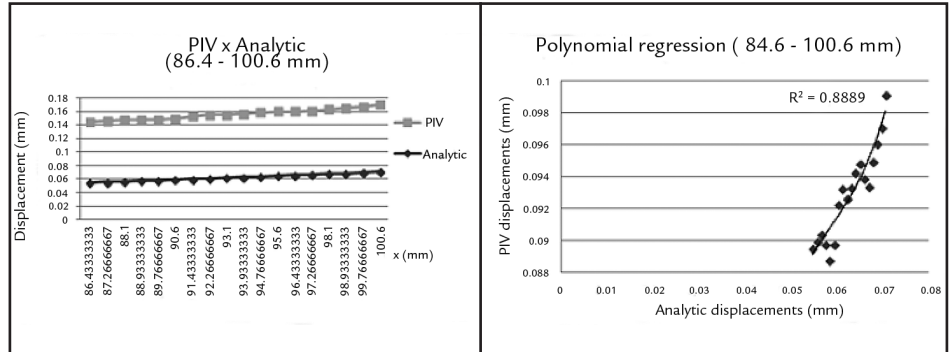
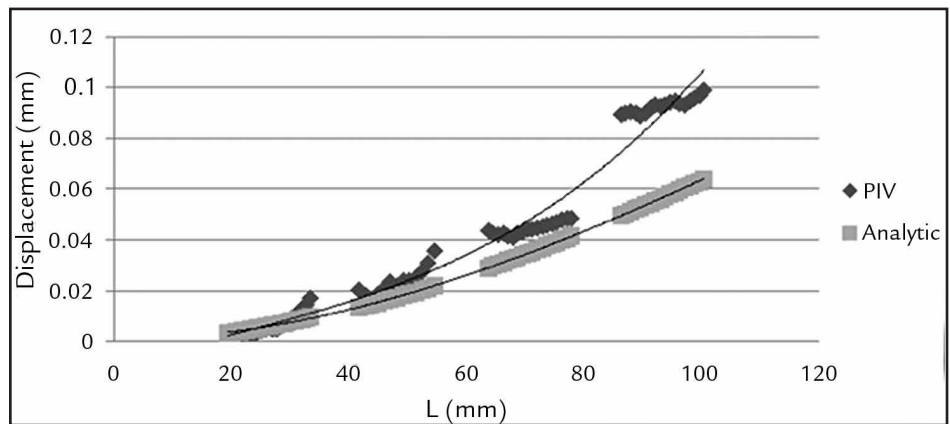

Figure 6 shows the results of the displacements comparing PIV and analytic

values covering almost the total length of the cantilever beam at each point mea-

sured due to the load of 1.96 N.

Figure 6
PIV vs. Analytic results
for total length of cantilever beam.



Considering almost the total length of the cantilever beam (Fig. 6), it is noted that as soon as PIV measured points increased the distance from the clamping position (zero x coordinate), the difference between PIV and analytic displacements values increased as well. It can be considered as a sensitivity output of the proposed measurement method and that would be considered an advantage for applications which require high sensitivity.

One advantage of this kind of

configuration is the absence of external particles in the sample, since the particles themselves are generated by the laser beam, thereby creating the grid of the speckle pattern that will be used as a high density source of particles. The high density source of the particles is responsible for the high sensitivity of the association of the PIV technique with the speckle pattern, where the sensitivity is related to the size of the grains formed in the surface, which can be adjusted by the distance between

the observer and the illuminated object.

An additional advantage of the proposed association (PIV and speckle) is the absence of a reference laser beam, as demanded in the holography and DSPI techniques.

Although the results displayed in this paper showed good fitness only for a specific load and limited positions, the methodology presented here could be extended to other geometries or materials.

4. Conclusions

A new method for measuring displacements in a cantilever beam by using particle image velocimetry associated to speckle laser patterns was proposed. Compared with analytical data, the

proposed method presented accurate measurements for a specific load (1.96 N) in positions close to the clamping (zero x coordinate). For the position between 19.54 mm and 33.41 mm, the

R-squared value was 0.99 for a 3rd order polynomial equation, which can be used in future studies involving optimization, such as finding best geometry or material properties from PIV measurement data.

In addition, PIV could be applied in an attempt to obtain non-contact displace-

ment measurements in solid mechanics with high sensibility, which has great

technological interest for new developments in non-destructive tests.

5. References

- ADRIAN, R.J. Particle imaging techniques for experimental fluid mechanics. *Ann. Rev. Fluid Mech.*, v.23, p.261-304, 1991.
- ADRIAN, R.J. Twenty years of particle image velocimetry. *Experiments in fluids*, v.39, p.159-169, 2005.
- ASTM A36 / A36M - 12. Standard Specification for Carbon Structural Steel. West Conshohocken, PA: ASTM, 2012.
- BABA, H.O., PETH, S. Large scale soil box test to investigate soil deformation and creep movement on slopes by Particle Image Velocimetry (PIV). *Soil & Tillage Research*, v. 125, p.38-43, 2012.
- BARCELOS, M.V. et alli. Analysis of mechanical behavior of a structural steel through torsion tests. *REM: Revista Escola de Minas*, v.66, n.3, p.317-322, 2013.
- DIAZ, F.V. et al. Determination of residual stresses using hole drilling and digital speckle pattern interferometry with automated data analysis. *Optics and Lasers in Engineering*, v.33, n.1, p.39-48, 2000.
- DYM, C.L., SHAMES, I.H. Solid mechanics, a variational approach. Augmented Edition, Springer New York, ISBN 978-1-4614-6034-3 (eBook), 2013. 685 p.
- ERTÜRK, N. et al. Small-scale characteristics and turbulent statistics of the flow in an external gear pump by time-resolved PIV. *Flow Measurement and Instrumentation*, v.29, p.52-60, 2013.
- HAMZA, O. et al. Biomechanics of plant roots: estimating localised deformation with particle image velocimetry. *Biosystems Engineering*, v.94, p.119-132, 2006.
- MAGALHAES, R.R. et al. The use of conventional strain gauges evaluation for measurements of residual stresses in welded joints. *Journal of the Brazilian Society of Mechanical Sciences and Engineering*, v.36, n.1, p.173-180, 2014.
- MAGALHAES, R.R. et al. Young's modulus evaluation using particle image velocimetry and finite element inverse analysis. *Optics and Lasers in Engineering*, v.70, p.33-37, 2015.
- RAFFEL M. et al. *Particle image velocimetry: a practical guide*. Berlin: Springer Verlag, 1998. 448 p.
- SOARES, et al. Biospeckle PIV (particle image velocimetry) for analyzing fluid flow. *Flow Measurement and Instrumentation*, v. 30, p.90-98, 2013.
- VOLKER W. et al. PIV measurements in environmental flows: recent experiences at the Institute for Hydromechanics in Karlsruhe. *Journal of Hydro-environment Research*, v.5, n.4, p.231-245, 2011.
- WHITE D.J. et al. Soil deformation measurement using particle image velocimetry (PIV) and photogrammetry. In: INTERNATIONAL CONFERENCE ON COMPUTER METHODS AND ADVANCES IN GEOMECHANICS, 10. v.53, n.7, p. 619-631, 2003.
- XU, D., CHEN, J. Accurate estimate of turbulent dissipation rate using PIV. *Experimental Thermal and Fluid Science*, v.44, p.662-672, 2013.

Received: 07 November 2013 - Accepted: 25 May 2015